

SPM-EM2XT2X-PXT

2 Fiber to X UTP 10/100/1000 Mbps Industrial POE Fiber Switch



Key Features

- 4 ~ 8 x 10/100/1000Mbps Auto-sensing RJ45 ports
- 2 x 1000Mbps SFP fiber ports
- 4 KV Ethernet surge protection, adapt to a harsh outdoor environment
- Support Auto MDI/MDIX
- Flow control mode: full duplex with IEEE 802.3x standard, half-duplex with Back pressure standard
- IEEE 802.3 10Base-T and IEEE 802.3u 100Base-TX compliant
- A store-and-forward switching mechanism
- Operating environment temperature:-40 ° ~ 85 ° c
- Intelligent power consumption detection and classification
- SW-Ring ring network patent technology (Fault recovery time<20ms, Only FX1 and FX2 support ring)
- IGMP Snooping, GMRP and static IGMP
- VLAN, PVLAN, control broadcast domain
- IEEE802.1p_QOS

- Port trunking, rate control, broadcast storm control
- SNMP, Telnet, WEB
- SSH,SSL,ACL, automatic MAC address bounding
- Support port mirroring
- Alarming: support ARP listening, power down, and ring-alarm
- Support link monitoring

Introduction

SPM-EM2XT2X-PXT is the 10/100/1000Mbps managed industrial fiber switch, operating temperature -40°C to $+85^{\circ}\text{C}$, support wide voltage dual power input, meet IP40 protection degree and EMC industrial grade requirements, DIN rail installation, pass through dangerous environmental certification and comply with FCC and CE standards. The reliable industrial grade design could ensure continuous and stable operation of the automation system.

Specification

Product Name	10/100/1000 Industrial POE Fiber Switch (2 Fiber to X UTP)
Model No.	SPM-EM2XT2X-PXT
Port	2 x 1000Mbps SFP ports SM: 1310nm/1550nm, 20Km 1490nm/1550nm, 40~120Km MM: 1310nm, 2Km 4 ~ 8 x 10/100/1000M UTP RJ45 (Support MDI/MDIX auto-sensing)
Switching features	Transmission mode: storage and forward System bandwidth: 2 SFPs + 4UTPs:12Gbps; 2 SFPs + 6UTPs:16Gbps; 2 SFPs + 8UTPs:20Gbps; (non-traffic jam)
Network media	10BASE-T: CAT3, CAT4, CAT5 un-shielded twisted pair($\leq 100\text{m}$) 100/1000BASE-TX: CAT5 or above shielded twisted pair($\leq 100\text{m}$) SFP port, transmission distance: 20Km, 40Km, 60Km, 80Km, 100Km
LEDs	Power, network, fiber
Power supply	Input voltage: DC 12-36V No-load power: 5W Reverse connection: support
Environment	Working temperature: $-40^{\circ}\text{C} \sim 85^{\circ}\text{C}$ Storage temperature: $-40^{\circ}\text{C} \sim 85^{\circ}\text{C}$ Working humidity: 10%~90%, non-condensing Storage humidity: 10%~95%, non-condensing
Industry Standards	EMI: FCC Part 15 Subpart B Class A, EN 55022 Class A EMS: EN 61000-4-2 (ESD) Level 3, EN 61000-4-3 (RS) Level 3, EN 61000-4-4 (EFT) Level 3, EN 61000-4-5 (Surge) Level 3, EN 61000-4-6 (CS) Level 3, EN 61000-4-8 Traffic Control: NEMA-TS2

	Vibration: IEC 60068-2-6 Freefall: IEC 60068-2-32 Shock: IEC 60068-2-27 Rail Traffic: EN 50121-4
Safety	CE Mark , commercial CE/LVD EN60950
Mechanical information	Shell: Corrugated metal shell Safety class: IP40 Dimension: 158 x 114.8 x 60mm Mounting method: Din-rail mounting
Warranty	Replacement within 1year; 5 years repairing

Application

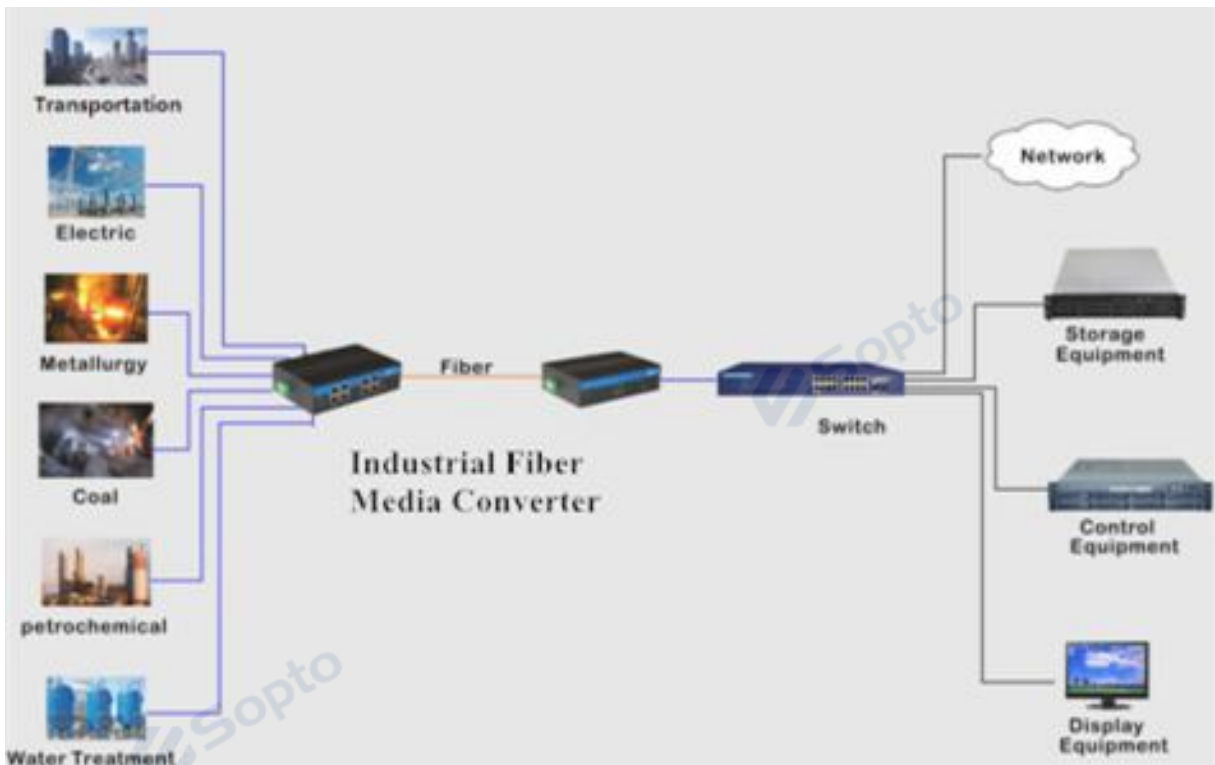

Ordering information

PN	Description
SPM-EM24T2X-PXT	Managed Gigabit Industrial Media Converter 4*10/100/1000Base-Tx to 2* SFP slot without SFP modules
SPM-EM26T2X-PXT	Managed Gigabit Industrial Media Converter 6*10/100/1000Base-Tx to 2* SFP slot without SFP modules
SPM-EM28T2X-PXT	Managed Gigabit Industrial Media Converter 8*10/100/1000Base-Tx to 2* SFP slot without SFP modules

Note: If you need more customized services, please contact us.

E-mail: info@sopto.com.cn

Web : <http://www.sopto.com.cn>