

SPT-XDXXTG-ER

10Gb/s 40km DWDM XFP Transceiver
Hot Pluggable, Duplex LC, 100GHz, DWDM EML, Single mode

Features

- Support multi protocol from 9.95Gb/s to 11.3Gb/s
- Hot pluggable 30 pin connector
- Compliant with XFP MSA
- Transmission distance of 40km over single mode fiber
- DWDM EML laser transmitter
- 100GHz ITU Grid, C Band
- Duplex LC connector
- 2-wire interface for management and diagnostic monitor
- XFI electrical interface with AC coupling
- Power supply voltages : +3.3V, +5V
- Temperature range 0°C to 70°C
- Power dissipation: <3.5W
- RoHS Compliant Part

Applications

- 10GBASE-ER/EW Ethernet
- SONET OC-192 /SDH
- 40km 10G FC
- DWDM Networks

Description

SOPTO's Small Form Factor 10Gb/s (XFP) transceivers are compliant with the current XFP Multi-Source Agreement (MSA) Specification. The high performance cooled DWDM TUNABLE transmitter and high sensitivity PIN receiver provide superior performance for SONET/SDH, 10G FC and Ethernet applications up to 40km optical links.

Absolute Maximum Ratings

| Parameter | Symbol | Min | Max | Unit |
|----------------------------|-----------------|-----|-----|------|
| Storage Temperature | T _{ST} | -40 | +85 | °C |
| Case Operating Temperature | T _{IP} | 0 | +70 | °C |

| | | | | |
|------------------|------------------|------|------|---|
| Supply Voltage 1 | V _{CC3} | -0.5 | +4.0 | V |
| Supply Voltage 2 | V _{CC5} | -0.5 | +6.0 | V |

Electrical Characteristics (TOP = 0 to 70 °C)

| Parameter | Symbol | Min | Typ | Max | Unit | Note | |
|--|------------------------|-----------------------|-----|---------------------|------|------|---|
| Supply Voltage 1 | V _{cc5} | 4.75 | | 5.25 | V | | |
| Supply Voltage 2 | V _{cc3} | 3.13 | | 3.45 | V | | |
| Supply Current – V _{cc5} supply | I _{cc5} | | | 250 | mA | | |
| Supply Current – V _{cc3} supply | I _{cc3} | | | 500 | mA | | |
| Module total power | P | | | 3.5 | W | | |
| Transmitter | | | | | | | |
| Input differential impedance | R _{in} | | 100 | | Ω | 1 | |
| Differential data input swing | V _{in,pp} | 150 | | 820 | mV | | |
| Transmit Disable Voltage | V _D | 2.0 | | V _{cc} | V | | |
| Transmit Enable Voltage | V _{EN} | GND | | GND+0.8 | V | | |
| Transmit Disable Assert Time | T _{off} | | | 100 | ms | | |
| Tx Enable Assert Time | T _{on} | | | 100 | ms | | |
| Receiver | | | | | | | |
| Differential data output swing | V _{out,pp} | 300 | 500 | 850 | mV | | |
| Data output rise time | t _r | | | 35 | ps | 2 | |
| Data output fall time | t _f | | | 35 | ps | 2 | |
| LOS Fault | V _{LOS fault} | V _{cc} – 0.5 | | V _{ccHOST} | V | 3 | |
| LOS Normal | V _{LOS norm} | GND | | GND+0.5 | V | 3 | |
| Power Supply Rejection | PSR | See Note 4 below | | | | | 4 |

Notes

1. After internal AC coupling.
2. 20 – 80 %
3. Loss of Signal is open collector to be pulled up with a 4.7k – 10kohm resistor to 3.15 – 3.6V. Logic 0 indicates normal operation; logic 1 indicates no signal detected.
4. Per Section 2.7.1. in the XFP MSA Specification.

Optical Parameters(TOP = 0 to 70 °C)

| Parameter | Symbol | Min | Typ | Max | Unit | Ref. |
|---------------------|--------|------|-----|-------|------|------|
| Transmitter | | | | | | |
| Operating Data Rate | BR | 9.95 | | 11.3 | Gb/s | |
| Bit Error Rate | BER | | | 10-12 | | |

| | | | | | | |
|---|------------------|---|---|-------|------|---|
| Maximum Launch Power | P_{MAX} | 0 | | +5 | dBm | 1 |
| Optical Wavelength-End Of Life | λ | X-100 | X | X+100 | pm | |
| Optical Wavelength-Beginning Of Life | λ | X-25 | X | X+25 | pm | |
| Optical Extinction Ratio | ER | 8.2 | | | dB | |
| Spectral Width@-20dB | $\Delta\lambda$ | | | 1 | nm | |
| Sidemode Supression ratio | SSRmin | 30 | | | dB | |
| Rise/Fall Time (20%~80%) | Tr/Tf | | | 35 | ps | |
| Average Launch power of OFF Transmitter | P_{OFF} | | | -30 | dBm | |
| Tx Jitter | T_{Xj} | Compliant with each standard requirements | | | | |
| Optical Eye Mask | | IEEE802.3ae | | | | 2 |
| Receiver | | | | | | |
| Operating Date Rate | BR | 9.95 | | 11.3 | Gb/s | |
| Receiver Sensitivity | Sen | | | -16 | dBm | 2 |
| Maximum Input Power | P_{MAX} | 0 | | | dBm | 2 |
| Optical Center Wavelength | λ_C | 1260 | | 1600 | nm | |
| Receiver Reflectance | Rrx | | | -27 | dB | |
| LOS De-Assert | LOS _D | | | -17 | dBm | |
| LOS Assert | LOS _A | -27 | | | dBm | |
| LOS Hysteresis | LOS _H | 0.5 | | 5 | dB | |

Notes:

1. The optical power is launched into SMF.
2. Measured with a PRBS $2^{31}-1$ test pattern @10.3125Gbps BER<10⁻¹².

Pin Definitions

Pin Assignment

Diagram of Host Board Connector Block Pin Numbers and Name

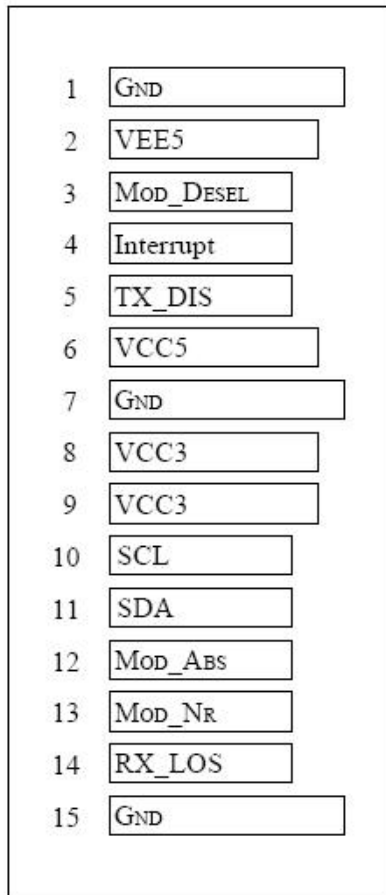

Bottom of Board
(As view through top of board)

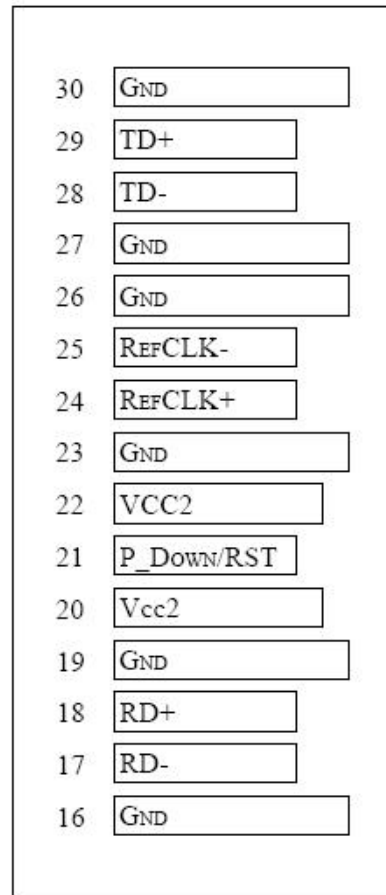

Top of Board

Pin Description:

| Pin | Logic | Symbol | Name/Description | Ref. |
|-----|---------|-----------|--|------|
| 1 | | GND | Module Ground | 1 |
| 2 | | VEE5 | Optional -5.2 Power Supply – Not required | |
| 3 | LVTTL-I | Mod-Desel | Module De-select; When held low allows the module to respond to 2-wire serial interface commands | |
| 4 | LVTTL-O | Interrupt | Interrupt (bar); Indicates presence of an important condition which can be read over the serial 2-wire interface | 2 |
| 5 | LVTTL-I | TX_DIS | Transmitter Disable; Transmitter laser source turned off | |
| 6 | | VCC5 | +5 Power Supply | |
| 7 | | GND | Module Ground | 1 |
| 8 | | VCC3 | +3.3V Power Supply | |
| 9 | | VCC3 | +3.3V Power Supply | |
| 10 | LVTTL-I | SCL | Serial 2-wire interface clock | 2 |

| | | | | |
|----|-----------|------------|--|---|
| 11 | LVTTL-I/O | SDA | Serial 2-wire interface data line | 2 |
| 12 | LVTTL-O | Mod_Abs | Module Absent; Indicates module is not present. Grounded in the module. | 2 |
| 13 | LVTTL-O | Mod_NR | Module Not Ready; | 2 |
| 14 | LVTTL-O | RX_LOS | Receiver Loss of Signal indicator | 2 |
| 15 | | GND | Module Ground | 1 |
| 16 | | GND | Module Ground | 1 |
| 17 | CML-O | RD- | Receiver inverted data output | |
| 18 | CML-O | RD+ | Receiver non-inverted data output | |
| 19 | | GND | Module Ground | 1 |
| 20 | | VCC2 | +1.8V Power Supply – Not required | |
| 21 | LVTTL-I | P_Down/RST | Power Down; When high, places the module in the low power stand-by mode and on the falling edge of P_Down initiates a module reset | |
| | | | Reset; The falling edge initiates a complete reset of the module including the 2-wire serial interface, equivalent to a power cycle. | |
| 22 | | VCC2 | +1.8V Power Supply – Not required | |
| 23 | | GND | Module Ground | 1 |
| 24 | PECL-I | RefCLK+ | Reference Clock non-inverted input, AC coupled on the host board – Not required | 3 |
| 25 | PECL-I | RefCLK- | Reference Clock inverted input, AC coupled on the host board – Not required | 3 |
| 26 | | GND | Module Ground | 1 |
| 27 | | GND | Module Ground | 1 |
| 28 | CML-I | TD- | Transmitter inverted data input | |
| 29 | CML-I | TD+ | Transmitter non-inverted data input | |
| 30 | | GND | Module Ground | 1 |

Note

1. Module circuit ground is isolated from module chassis ground within the module.
2. Open collector; should be pulled up with 4.7k – 10k ohms on host board to a voltage between 3.15V and 3.45V.
3. A Reference Clock input is not required.

Digital Diagnostic Functions

As defined by the XFP MSA 1, SOPTO's XFP transceivers provide digital diagnostic functions via a 2-wire serial interface, which allows real-time access to the following operating parameters:

- ✓ Transceiver temperature
- ✓ Laser bias current
- ✓ Transmitted optical power
- ✓ Received optical power
- ✓ Transceiver supply voltage

It also provides a sophisticated system of alarm and warning flags, which may be used to alert end-users when particular operating parameters are outside of a factory-set normal range.

The operating and diagnostics information is monitored and reported by a Digital Diagnostics Transceiver Controller (DDTC) inside the transceiver, which is accessed through the 2-wire serial interface. When the serial protocol is activated, the serial clock signal (SCL pin) is generated by the host. The positive edge clocks data into the XFP transceiver into those segments of its memory map that are not write-protected. The negative edge clocks data from the XFP transceiver. The serial data signal (SDA pin) is bi-directional for serial data transfer. The host uses SDA in conjunction with SCL to mark the start and end of serial protocol activation. The memories are organized as a series of 8-bit data words that can be addressed individually or sequentially. The 2-wire serial interface provides sequential or random access to the 8 bit parameters, addressed from 000h to the maximum address of the memory.

For more detailed information including memory map definitions, please see the XFP MSA Specification.

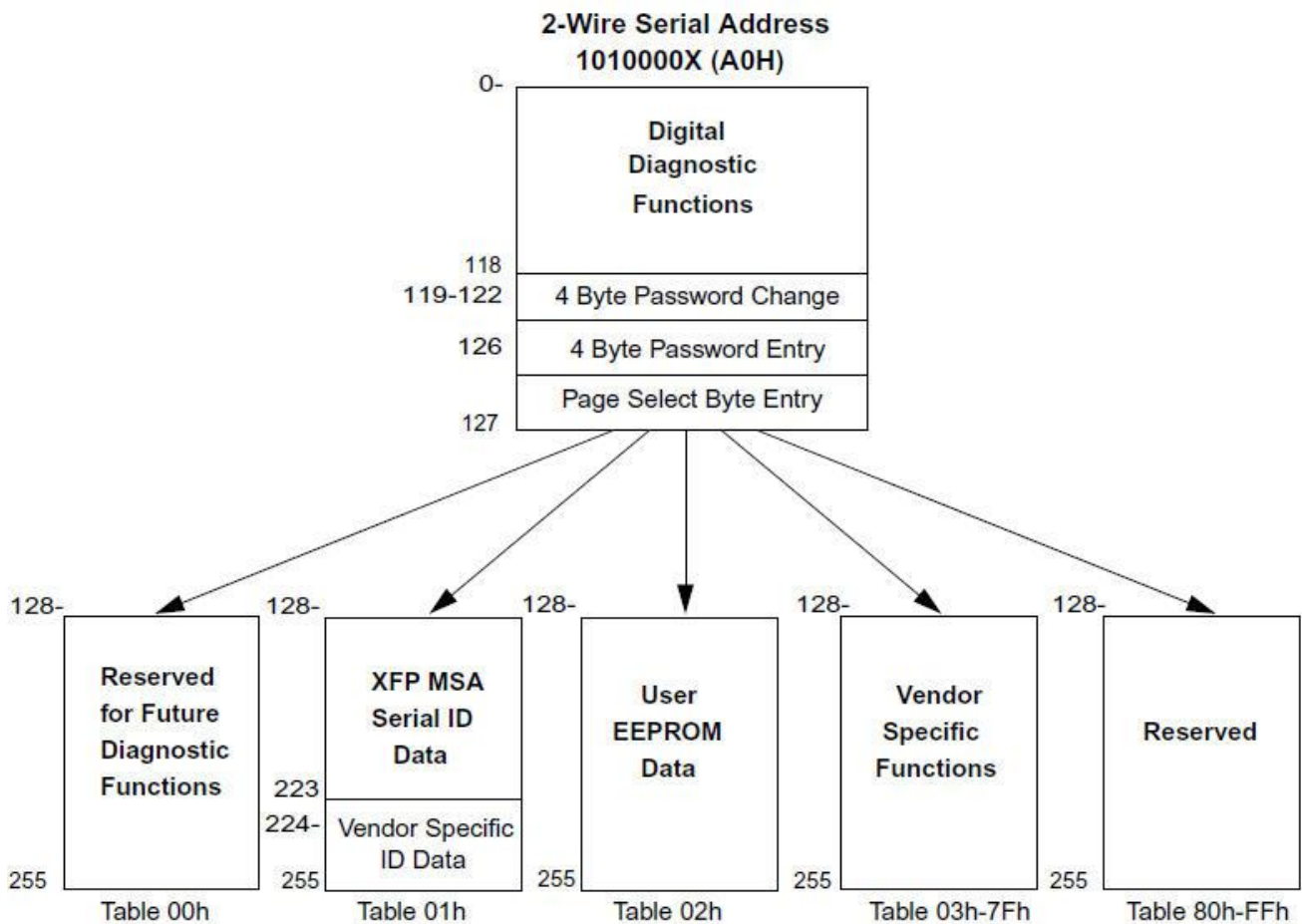

Recommended Circuit

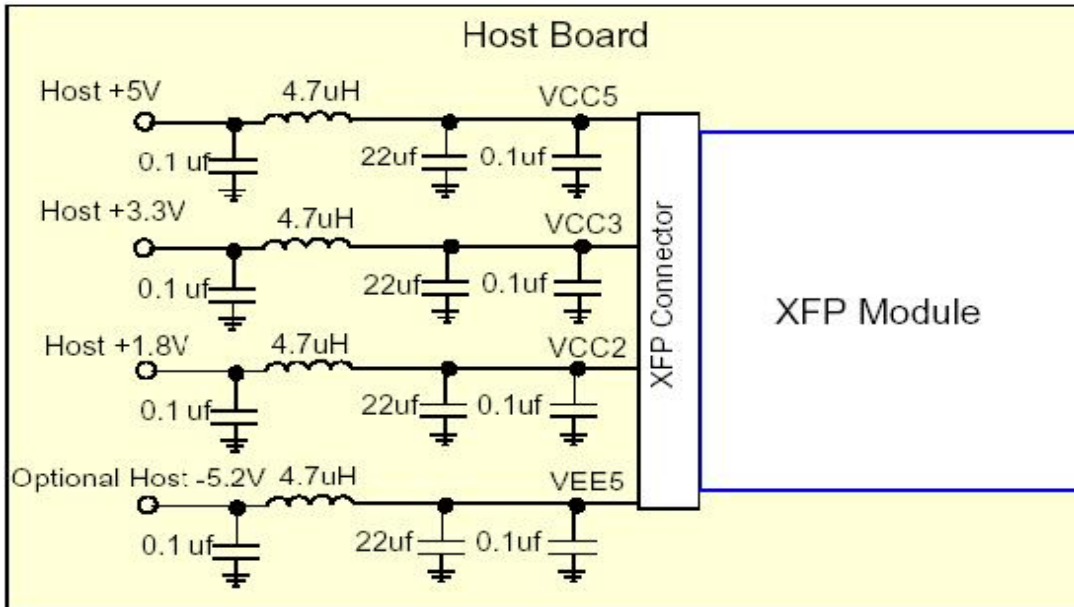

Recommended Host Board Power Supply Circuit

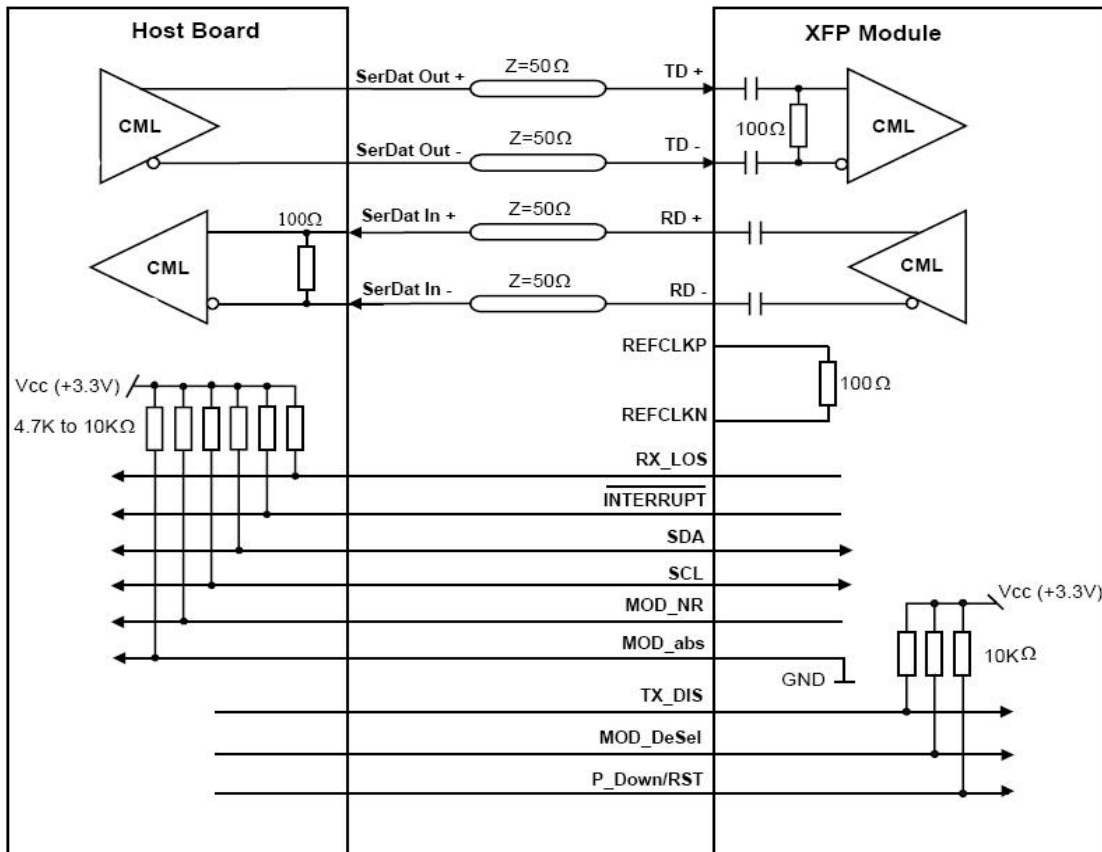

Recommended High-speed Interface Circuit

Mechanical Dimensions

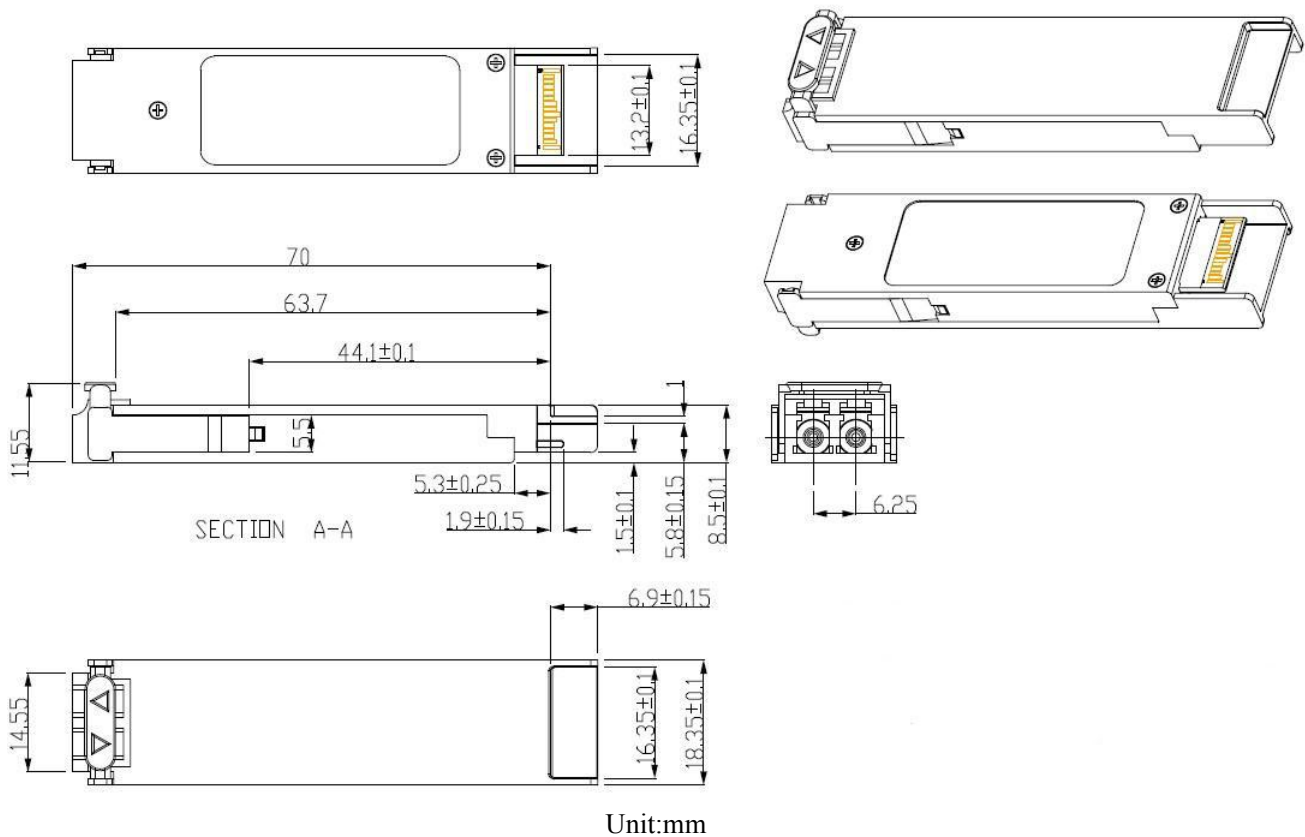

Ordering information

| Part Number | Product Description |
|---------------|---|
| SPT-XDXXTG-ER | DWDM XFP, 10Gbps, 40km, 0°C ~ +70°C, With DDM |

Note: XX = 17~61 (ITU Channel C-band)

| C-band | Central Wavelength(nm) | Frequency (THZ) |
|--------|------------------------|-----------------|
| C61 | 1528.77 | 196.1 |
| C60 | 1529.55 | 196.0 |
| C59 | 1530.33 | 195.9 |
| C58 | 1531.12 | 195.8 |
| C57 | 1531.90 | 195.7 |
| C56 | 1532.68 | 195.6 |
| C55 | 1533.47 | 195.5 |
| C54 | 1534.25 | 195.4 |
| C53 | 1535.04 | 195.3 |
| C52 | 1535.82 | 195.2 |
| C51 | 1536.61 | 195.1 |
| C50 | 1537.40 | 195.0 |
| C49 | 1538.19 | 194.9 |
| C48 | 1538.98 | 194.8 |

| | | |
|-----|---------|-------|
| C47 | 1539.77 | 194.7 |
| C46 | 1540.56 | 194.6 |
| C45 | 1541.35 | 194.5 |
| C44 | 1542.14 | 194.4 |
| C43 | 1542.94 | 194.3 |
| C42 | 1543.73 | 194.2 |
| C41 | 1544.53 | 194.1 |
| C40 | 1545.32 | 194.0 |
| C39 | 1546.12 | 193.9 |
| C38 | 1546.92 | 193.8 |
| C37 | 1547.72 | 193.7 |
| C36 | 1548.51 | 193.6 |
| C35 | 1549.32 | 193.5 |
| C34 | 1550.12 | 193.4 |
| C33 | 1550.92 | 193.3 |
| C32 | 1551.72 | 193.2 |
| C31 | 1552.52 | 193.1 |
| C30 | 1553.33 | 193.0 |
| C29 | 1554.13 | 192.9 |
| C28 | 1554.94 | 192.8 |
| C27 | 1555.75 | 192.7 |
| C26 | 1556.55 | 192.6 |
| C25 | 1557.36 | 192.5 |
| C24 | 1558.17 | 192.4 |
| C23 | 1558.98 | 192.3 |
| C22 | 1559.79 | 192.2 |
| C21 | 1560.61 | 192.1 |
| C20 | 1561.42 | 192.0 |
| C19 | 1562.23 | 191.9 |
| C18 | 1563.05 | 191.8 |
| C17 | 1563.86 | 191.7 |

Note: If you need more customized services, please contact us.

SOPTO reserves the right to make changes to the products or information contained herein without notice. No liability is assumed as a result of their use or application. No rights under any patent accompany the sale of any such products or information.

Published by Shenzhen SOPTO Technology Co., Ltd.

Copyright © SOPTO

All Rights Reserved

E-mail: info@sopto.com.cn

Web : <http://www.sopto.com.cn>