



10Gb/s 20km BiDi XFP Transceiver

Hot Pluggable, Single LC, 1270/1330nm, CWDM DFB, Single mode

Features

- Supports 9.95Gb/s to 11.3Gb/s bit rates
- Hot-pluggable XFP footprint
- Single LC for Bi-directional Transmission
- Maximum link length of 20km
- Built-in 1270/1330 WDM
- Uncooled 1270nm or 1330nm CWDM DFB Laser.
- Power dissipation <2W
- No Reference Clock required
- Built-in digital diagnostic functions
- Temperature range Standard: 0 to +70°C , Industrial: -40 to +85°C
- Very low EMI and excellent ESD protection
- RoHS Compliant Part

Applications

- 10GBASE-LR/LW Ethernet
- SONET OC-192 /SDH
- 1200-SM-LL-L 10G Fibre Channel

Description

SOPTO 20km 2733/3327 Bi-directional 10Gb/s (XFP) transceivers are compliant with the current XFP Multi-Source Agreement (MSA) Specification. They comply with 10-Gigabit Ethernet 10GBASE-LR/LW per IEEE 802.3ae, SONET OC-192 /SDH and 10G Fibre Channel 1200-SM-LL-L. Digital diagnostics functions are available via a 2-wire serial interface, as specified in the XFP MSA.

Absolute Maximum Ratings

Parameter	Symbol	Min	Max	Unit
-----------	--------	-----	-----	------

Storage Temperature	T_{ST}		-40	+85	°C
Case Operating Temperature	T_{IP}	Standard	0	+70	°C
		Industrial	-40	+85	
Supply Voltage	V_{CC3}		-0.5	+4.0	V

Electrical Characteristics (TOP = 0 to 70 °C)

Parameter	Symbol	Min	Typ	Max	Unit	Note	
Supply Voltage	V_{CC3}	3.13		3.45	V		
Supply Current	I_{CC3}			500	mA		
Module total power	P			2	W		
Transmitter							
Input differential impedance	R_{in}		100		Ω	1	
Differential data input swing	$V_{in,pp}$	150		820	mV		
Transmit Disable Voltage	V_D	2.0		V_{CC}	V		
Transmit Enable Voltage	V_{EN}	GND		GND+0.8	V		
Transmit Disable Assert Time	T_{off}			100	ms		
Tx Enable Assert Time	T_{on}			100	ms		
Receiver							
Differential data output swing	$V_{out,pp}$	300	500	850	mV		
Data output rise time	t_r			35	ps	2	
Data output fall time	t_f			35	ps	2	
LOS Fault	$V_{LOS\ fault}$	$V_{CC} - 0.5$		V_{CCHOST}	V	3	
LOS Normal	$V_{LOS\ norm}$	GND		GND+0.5	V	3	
Power Supply Rejection	PSR	See Note 4 below					4

Notes

1. After internal AC coupling.
2. 20 – 80 %
3. Loss of Signal is open collector to be pulled up with a 4.7k – 10kohm resistor to 3.15 – 3.6V. Logic 0 indicates normal operation; logic 1 indicates no signal detected.
4. Per Section 2.7.1. in the XFP MSA Specification.

Optical Parameters(TOP = 0 to 70°C)

Parameter	Symbol	Min	Typ	Max	Unit	Ref.
Transmitter						
Operating Data Rate	BR	9.95		11.3	Gb/s	
Bit Error Rate	BER			10^{-12}		
Maximum Launch Power	P_{MAX}	-3		+2	dBm	1
Optical Center	1270nmTX	λ	1260	1270	1280	nm

Wavelength	1330nmTX		1320	1330	1340			
Optical Extinction Ratio	ER	3.5				dB		
Spectral Width	$\Delta\lambda$				1	nm		
Sidemode Supression ratio	SSRmin	30				dB		
Rise/Fall Time (20%~80%)	Tr/Tf				50	ps		
Average Launch power of OFF Transmitter	P _{OFF}				-30	dBm		
Tx Jitter	T _{xj}	Compliant with each standard requirements						
Optical Eye Mask		IEEE802.3ae						2
Receiver								
Operating Date Rate	BR	9.95			11.3	Gb/s		
Receiver Sensitivity	Sen				-14.5	dBm	2	
Maximum Input Power	P _{MAX}	0				dBm	2	
Optical Center Wavelength	1330nmRX	λ_c	1320	1330	1340	nm		
	1270nmRX		1260	1270	1280			
Receiver Reflectance	R _{rx}				-14	dB		
LOS De-Assert	LOS _D				-15	dBm		
LOS Assert	LOS _A	-30				dBm		
LOS Hysteresis	LOS _H	0.5			5	dB		

Notes:

1. The optical power is launched into SMF.
2. Measured with a PRBS 2³¹-1 test pattern @10.3125Gbps BER<10⁻¹².

Pin Assignment

Diagram of Host Board Connector Block Pin Numbers and Name

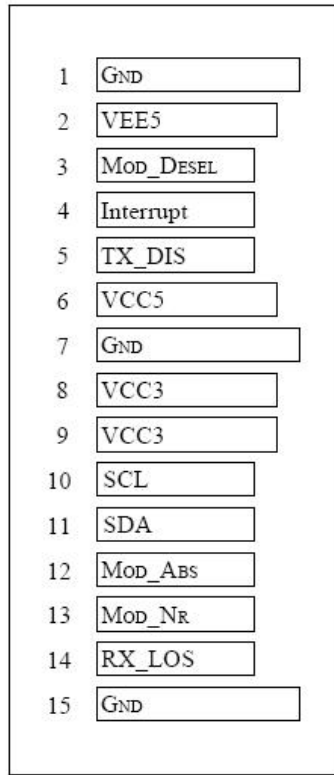

Bottom of Board
(As view through top of board)

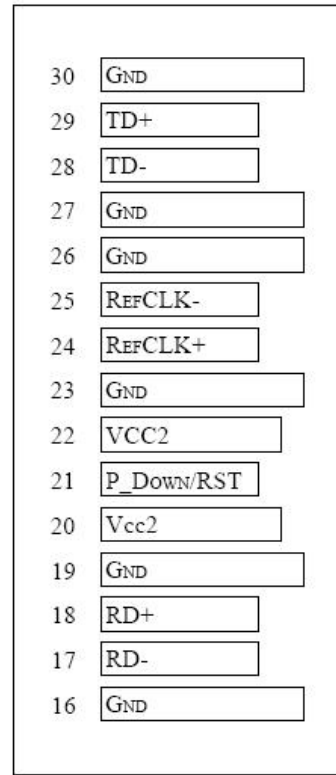

Top of Board

Pin Function Definitions

Pin	Logic	Symbol	Name/Description	Ref.
1		GND	Module Ground	1
2		VEE5	Optional -5.2 Power Supply – Not required	
3	LVTTL-I	Mod-Desel	Module De-select; When held low allows the module to respond to 2-wire serial interface commands	
4	LVTTL-O	Interrupt	Interrupt (bar); Indicates presence of an important condition which can be read over the serial 2-wire interface	2
5	LVTTL-I	TX_DIS	Transmitter Disable; Transmitter laser source turned off	
6		VCC5	+5 Power Supply	
7		GND	Module Ground	1
8		VCC3	+3.3V Power Supply	
9		VCC3	+3.3V Power Supply	
10	LVTTL-I	SCL	Serial 2-wire interface clock	2
11	LVTTL-I/O	SDA	Serial 2-wire interface data line	2
12	LVTTL-O	Mod_Abs	Module Absent; Indicates module is not present. Grounded in the module.	2
13	LVTTL-O	Mod_NR	Module Not Ready;	2

14	LVTTTL-O	RX_LOS	Receiver Loss of Signal indicator	2
15		GND	Module Ground	1
16		GND	Module Ground	1
17	CML-O	RD-	Receiver inverted data output	
18	CML-O	RD+	Receiver non-inverted data output	
19		GND	Module Ground	1
20		VCC2	+1.8V Power Supply – Not required	
21	LVTTTL-I	P_Down/R_ST	Power Down; When high, places the module in the low power stand-by mode and on the falling edge of P_Down initiates a module reset	
			Reset; The falling edge initiates a complete reset of the module including the 2-wire serial interface, equivalent to a power cycle.	
22		VCC2	+1.8V Power Supply – Not required	
23		GND	Module Ground	1
24	PECL-I	RefCLK+	Reference Clock non-inverted input, AC coupled on the host board – Not required	3
25	PECL-I	RefCLK-	Reference Clock inverted input, AC coupled on the host board – Not required	3
26		GND	Module Ground	1
27		GND	Module Ground	1
28	CML-I	TD-	Transmitter inverted data input	
29	CML-I	TD+	Transmitter non-inverted data input	
30		GND	Module Ground	1

Note

1. Module circuit ground is isolated from module chassis ground within the module.
2. Open collector; should be pulled up with 4.7k – 10k ohms on host board to a voltage between 3.15V and 3.45V.
3. A Reference Clock input is not required.

Digital Diagnostic Functions

As defined by the XFP MSA 1, FTTX's XFP transceivers provide digital diagnostic functions via a 2-wire serial interface, which allows real-time access to the following operating parameters:

- ✓ Transceiver temperature
- ✓ Laser bias current
- ✓ Transmitted optical power
- ✓ Received optical power
- ✓ Transceiver supply voltage

It also provides a sophisticated system of alarm and warning flags, which may be used to alert end-users when particular operating parameters are outside of a factory-set normal range.

The operating and diagnostics information is monitored and reported by a Digital Diagnostics Transceiver Controller (DDTC) inside the transceiver, which is accessed through the 2-wire serial interface. When the serial protocol is activated, the serial clock signal (SCL pin) is generated by the host. The positive edge clocks data into the XFP transceiver into those segments of its memory map that are not write-protected. The negative edge clocks data from the XFP transceiver. The serial data signal (SDA pin) is bi-directional for serial data transfer. The host uses SDA in conjunction with SCL to mark the start and end of serial



protocol activation. The memories are organized as a series of 8-bit data words that can be addressed individually or sequentially. The 2-wire serial interface provides sequential or random access to the 8 bit parameters, addressed from 000h to the maximum address of the memory.

For more detailed information including memory map definitions, please see the XFP MSA Specification.

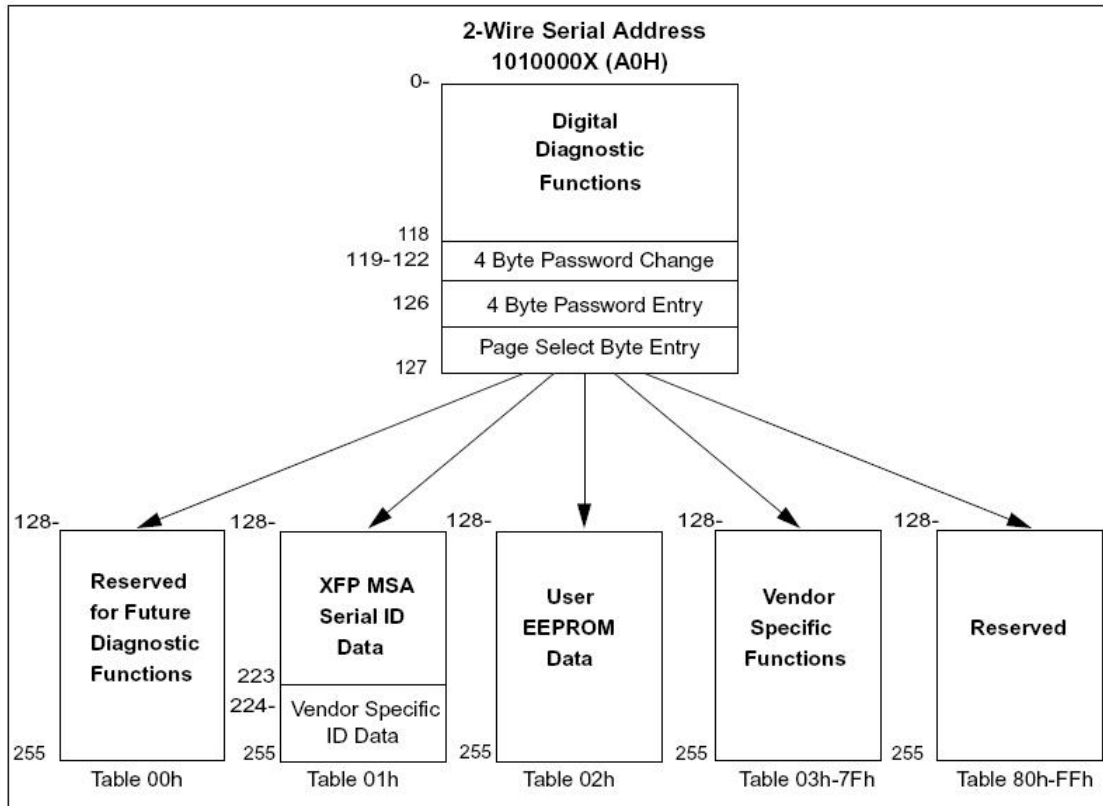

Recommended Circuit

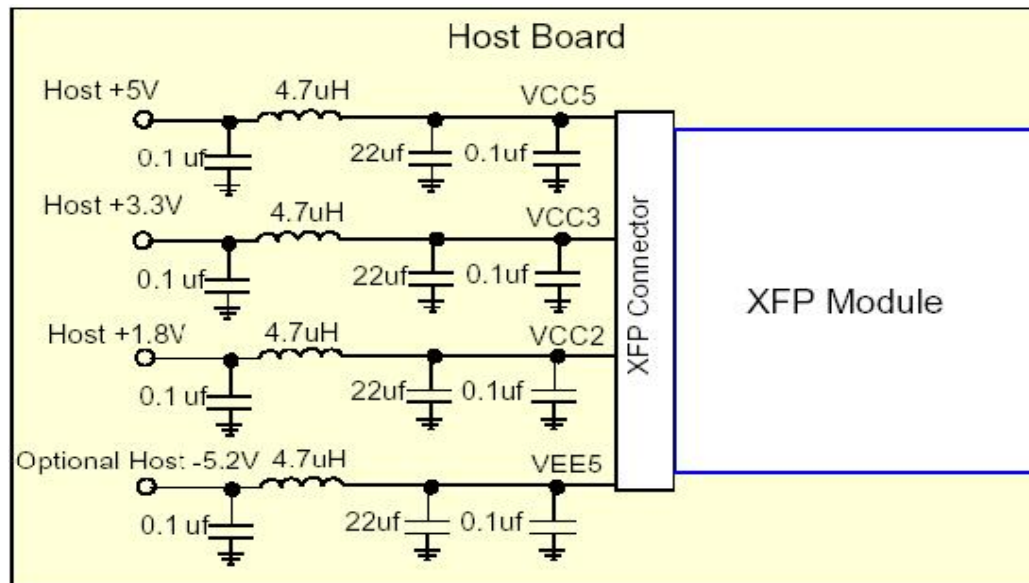

Recommended Host Board Power Supply Circuit

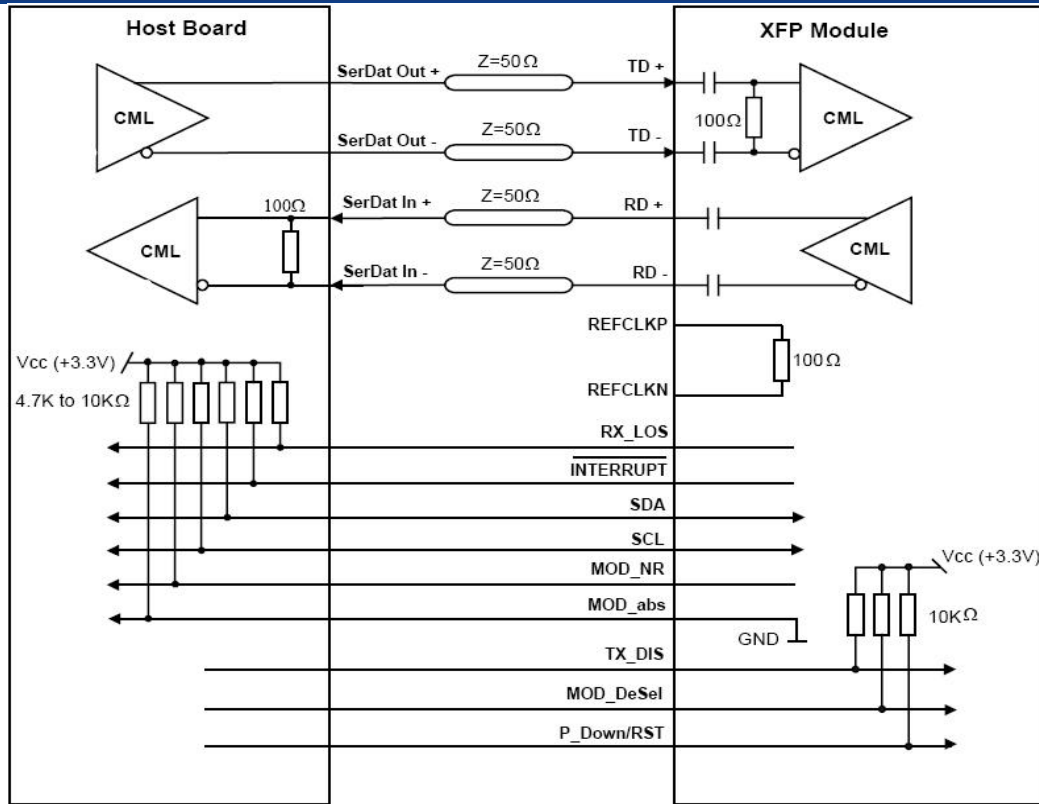

Recommended High-speed Interface Circuit

Mechanical Dimensions

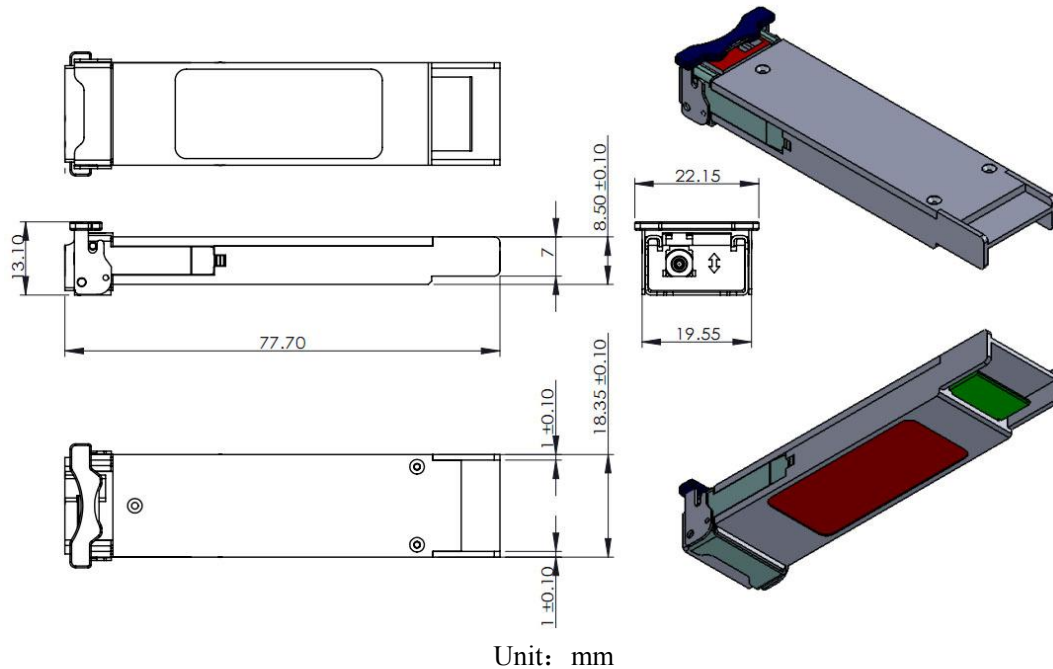

Ordering information

Part Number	Product Description
SPT-XB2733TG-L20	Transceiver XFP Single Fiber BIDI 1270nmTx/1330nmRx 10G LC Interface 20km with DDM Commercial Temperature

SPT-XB3327TG-L20	Transceiver XFP Single Fiber BIDI 1330nmTx/1270nmRx 10G LC Interface 20km with DDM Commercial Temperature
SPT-XB2733TG-L20T	Transceiver XFP Single Fiber BIDI 1270nmTx/1330nmRx 10G LC Interface 20km with DDM Industrial Temperature
SPT-XB3327TG-L20T	Transceiver XFP Single Fiber BIDI 1330nmTx/1270nmRx 10G LC Interface 20km with DDM Industrial Temperature

Note: If you need more customized services, please contact us.

E-mail: info@sopto.com.cn

Web : <http://www.sopto.com.cn>