

# SPT-X85TG-SR

## 10Gbps XFP Optical Transceiver, 300m Reach

### Features

- Supports 9.95Gbps to 10.5Gbps bit rates
- Maximum link length of 300m /OM3,400m/OM4
- 850nm VCSEL laser and PIN receiver
- Low power consumption <1.5W
- +5V, +3.3V power supply
- XFP MSA package with duplex LC connector
- XFI electrical interface
- No reference clock required
- Compatible with RoHS
- Excellent EMI performance
- Built-in digital diagnostic functions
- Temperature range: 0°C to +70°C
- High reliability

### Applications

- 10GBASE-SR/SW 10G Ethernet
- 1200-Mx-SN-I 10G Fiber Channel
- Other optical links

### General Description

It is compliant with the 10G Small Form-Factor Pluggable (XFP) Multi-Source Agreement (MSA), supporting data-rate of 10.3125Gbps(10GBASE-LR) or 9.953Gbps 10GBASE-LW), and transmission distance up to 300m on 50µm MMF (2000MHz\*km),400m on 50µm MMF (4700MHz\*km).

The transceiver module comprises a transmitter with 850nm a vertical cavity surface emitting (VCSEL) laser and a receiver with a PIN photodiode. Transmitter and receiver are separate within a wide temperature range of 0 °C to +70 °C and offers optimum heat dissipation and excellent electromagnetic shielding thus enabling high port densities for 10 GbE systems.

## Absolute Maximum Ratings

Rating	Symbol	Min	Max	Units	Ref.
Storage Ambient Temperature Range		-40	+85	°C	
Powered case Temperature Range		-5	+70	°C	
Operating Relative Humidity	RH		80	%	
Supply Voltage Range @ 5V	Vcc5	-0.5	6.0	V	
Supply Voltage Range @ 3.3V	Vcc3	-0.5	4.0	V	
Static Discharge Voltage on XFI High			500	V	1
Static Discharge Voltage excluding XFI High Speed Pins			2,000	V	2
Static Discharge Voltage on XFP Module			15,000 8,000	V V	3

Any stress beyond the maximum ratings can result in permanent damage. The device specifications are guaranteed only under the recommended operating conditions.

### Notes:

- 1, HBM human body model per JEDEC JESD22-A114-B.
- 2, HBM human body model.
- 3, EN61000-4-2 Criterion B: Air Discharge Direct Contact discharge

## Recommend operating condition

Parameter	Symbol	Min	Typ	Max	Units	Ref.
Operating Case Temperature Range	Tc	0		+70	°C	
Transceiver total Power on Sumption	PTOT			1.5	W	1
Power Supply Voltage @ 5V	Vcc5	4.75	5.0	5.25	V	
Power Supply Voltage @ 3.3V	Vcc3	3.13	3.3	3.4	V	

### Notes:

- 1, Maximum total power value is specified across the full temperature and voltage range.

## Electrical Characteristics

Parameter	Symbol	Min	Typ	Max	Unit	Note
<b>Transmitter</b>						
Input Differential Impedance	RIND		100		Ω	1
Differential input Voltage Swing	VID	120		1000	mV	2
Transmit Disable Voltage	VDis	2.0		VCC		
Transmit Enable Voltage	VEN	GND		GND+0.8		

Transmit Disable Assert Time				10		
Receiver						
Differential Output Impedance	ZOD		100		$\Omega$	
Differential Output Amplitude	VOSPP	500		800	mV	3
Transition Time Low to High	t r	40			ps	4
Transition Time High to Low	t f	40			ps	4
LOS Fault	L fault	Vcc-0.5		VCCHOS	V	5
LOS Normal	L normal	GND		GND+0.5	V	3

**Notes:**

- 1, After internal AC coupling.
- 2, Beneath this level the signal can't meet the specification
- 3, into 100 ohms differential termination.
- 4, 20 – 80 %.
- 5, Loss Of Signal is open collector to be pulled up with a 4.7k $\Omega$  – 10k $\Omega$  resistor to 3.15 – 3.6V. Logic 0 indicates normal operation; logic 1 indicates no signal detected.

## Optical Characteristics

Parameter	Symbol	Min	Typ	Max	Unit	Ref.
Transmitter						
Nominal Wavelength	TRP	840	850	860	nm	
Spectral Width	$\Delta\lambda$		0.4	0.45	nm	
Average Power	Po	-5		-1	dBm	1
Extinction Ratio	ER	3			dB	2
Relative Intensity Noise	RIN			-128	dB/Hz	
Receiver						
Center Wavelength	$\lambda_C$	840	850	860	Nm	
Receiver Sensitivity	PIN			-9.9	dBm	3
Receiver Sensitivity in	PIN			-11	dBm	3
Receiver Overload	Pin			0	dBm	3
Receiver Reflectance				-12	dBm	
LOS De-Assert	LOSD			-13	dBm	
LOS Assert	LOSA	-23			dBm	
LOS Hysteresis		0.5			dB	

**Notes:**

1. Launched into MMF
2. Measured with PRBS  $2^{31}-1$  @10.3125Gbps

3. Measured with PRBS 2<sup>31</sup>-1 @10.3125Gbps with ideal transmitter  
 The specified characteristics are met within the recommended range of operating conditions and under the default settings of output power and modulation amplitude. A change in setting of the optical output power influences especially the dynamic behavior of the output signal. Unless otherwise noted typical data are quoted at nominal voltages and +25°C ambient temperature.

### General

Parameter	Conditions	Min Modal Bandwidth (MHz*Km)	Symbol	Min	Typ	Max	Units	Ref.
Operating Range	62.5/125µm MMF	160	IOP	2		26	m	
	50/125µm MMF	400				66		
	62.5/125µm MMF	200				33		
	50/125µm MMF	500				82		
	50/125µm MMF	2000				300		
	50/125µm MMF	4700				400		
Bit Rate			BR	9.95		10.5	Gbps	1
Bit Error Ratio			BER			10 <sup>-12</sup>		2

Notes:

- 10GBASE-SR/SW, 1200-Mx-SN-I
- Tested with a 2<sup>31</sup> – 1 PRBS

### Hostboard Connector Pinout

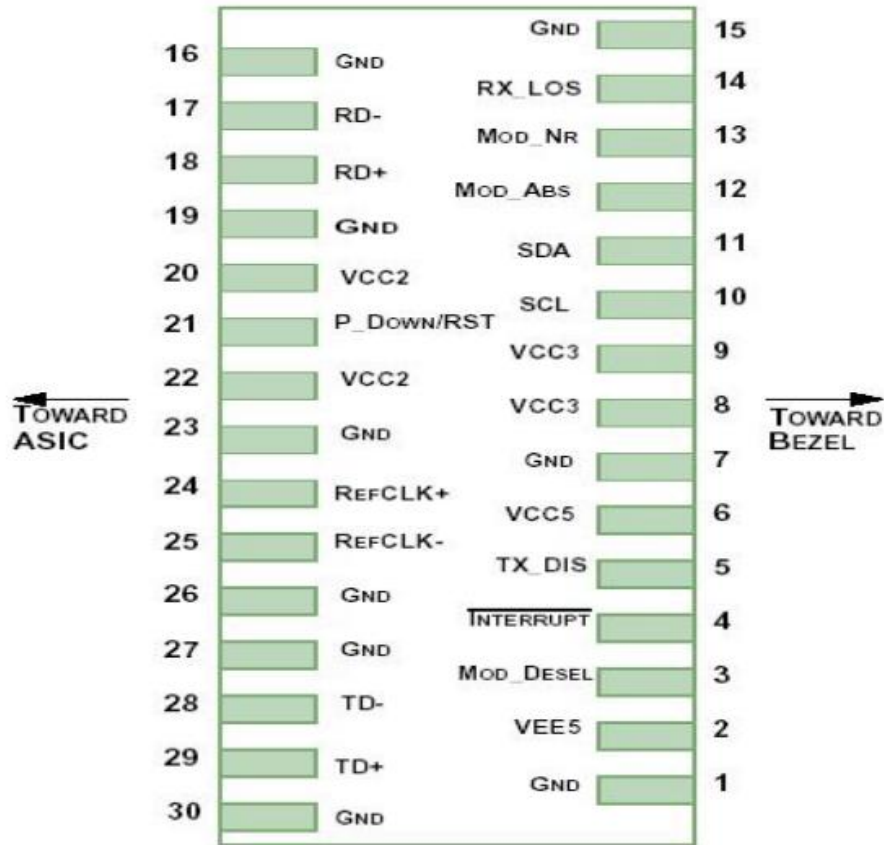

Pin	Logic	Symbol	Name/Description	Ref.
1		GND	Module Ground	1
2		VEE5	Optional -5.2 Power Supply – Not required	
3	LVTTL-I	Mod-Desel	Module De-select; When held low allows the module to respond to 2-wire serial interface commands	
4	LVTTL-O	Interrupt	Interrupt (bar); Indicates presence of an important condition which can be read over the serial 2-wire interface	2
5	LVTTL-I	TX_DIS	Transmitter Disable; Transmitter laser source turned off	
6		VCC5	+5 Power Supply	
7		GND	Module Ground	1
8		VCC3	+3.3V Power Supply	
9		VCC3	+3.3V Power Supply	
10	LVTTL-I	SCL	Serial 2-wire interface clock	2
11	LVTTL-I/O	SDA	Serial 2-wire interface data line	2
12	LVTTL-O	Mod_Abs	Module Absent; Indicates module is not present. Grounded in the module.	2
13	LVTTL-O	Mod_NR	Module Not Ready	2



14	LVTTL-O	RX_LOS	Receiver Loss of Signal indicator	2
15		GND	Module Ground	1
16		GND	Module Ground	1
17	CML-O	RD-	Receiver inverted data output	
18	CML-O	RD+	Receiver non-inverted data output	
19		GND	Module Ground	1
20		VCC2	+1.8V Power Supply	
21	LVTTL-I	P_Down/ RST	Power Down; When high, places the module in the low power stand-by mode and on the falling edge of P_Down initiates a module reset	
			Reset; The falling edge initiates a complete reset of the module including the 2-wire serial interface, equivalent to a power cycle.	
22		VCC2	+1.8V Power Supply	
23		GND	Module Ground	1
24	PECL-I	RefCLK+	Reference Clock non-inverted input, AC coupled on the host board – <b>Not required</b>	3
25	PECL-I	RefCLK-	Reference Clock inverted input, AC coupled on the host board – <b>Not required</b>	3
26		GND	Module Ground	1
27		GND	Module Ground	1
28	CML-I	TD-	Transmitter inverted data input	
29	CML-I	TD+	Transmitter non-inverted data input	
30		GND	Module Ground	1

Notes:

- 1, Module ground pins GND are isolated from the module case and chassis ground within the module.
- 2, Shall be pulled up with 4.7kΩ-10 kΩ to a voltage between 3.15V and 3.45V on the host board.

## Management Interface

The transceivers provide serial ID memory contents and diagnostic information about the present operating conditions by the 2-wire serial interface (SCL, SDA).

The Module provides diagnostic information about the present operating conditions. The transceiver generates this diagnostic data by digitization of internal analog signals. Alarm/warning threshold data is written during device manufacture. Received power monitoring, transmitted power monitoring, bias current monitoring, supply voltage monitoring and temperature monitoring all are implemented.

The digital diagnostic memory map specific data field defines as following.

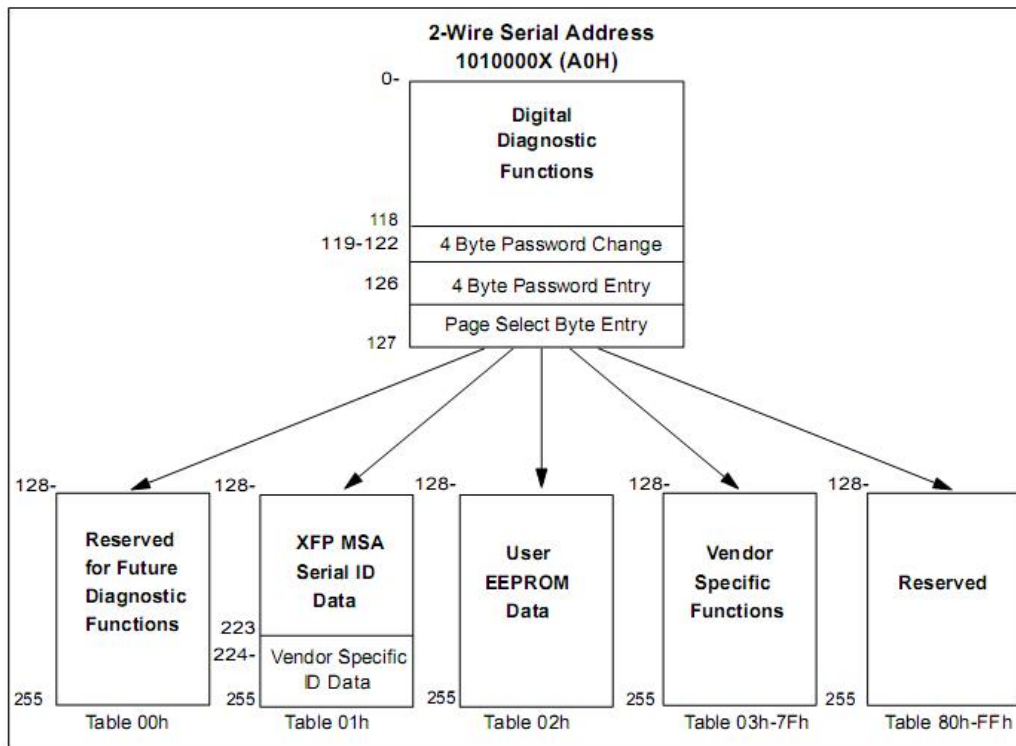

### Recommended Host Board Power Supply Circuit

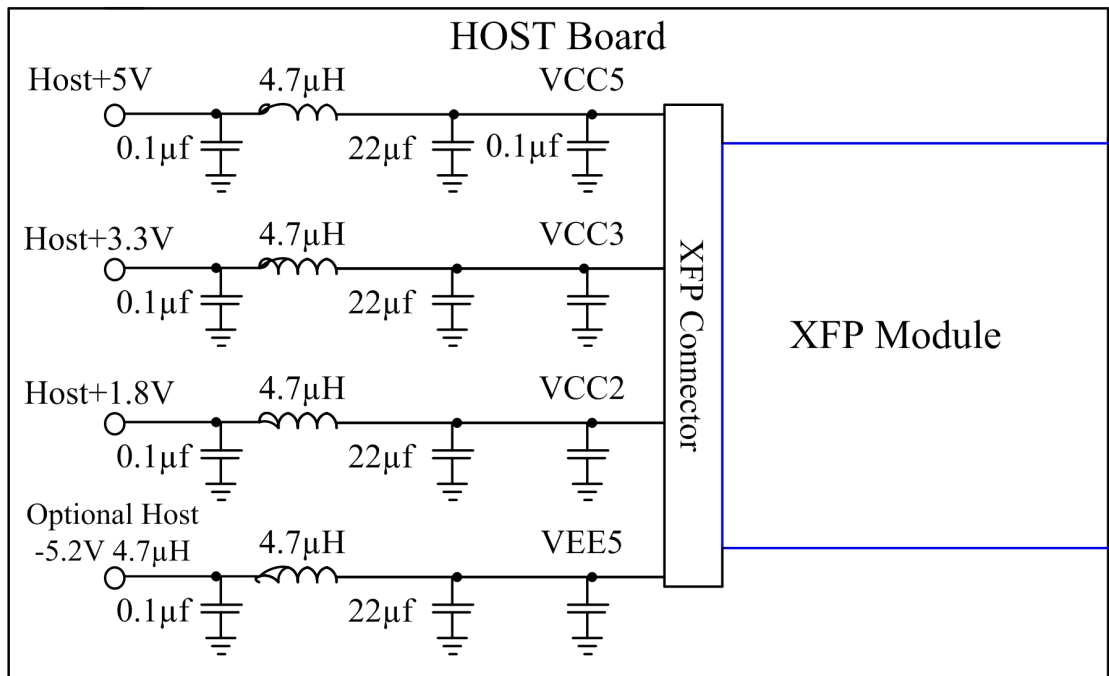

### Recommended High-speed Interface Circuit



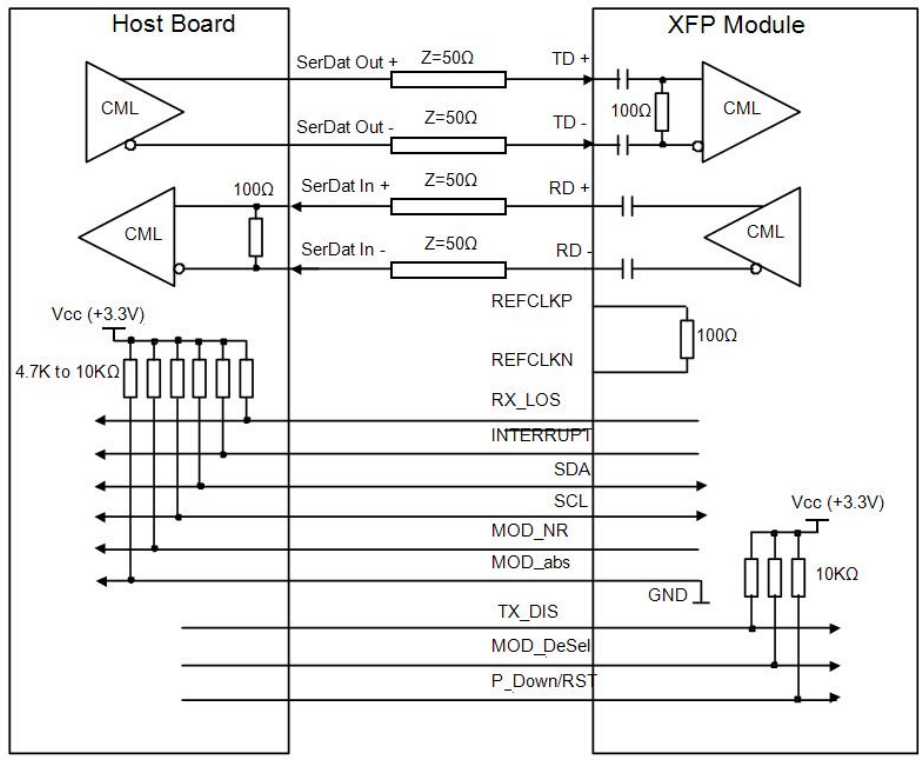

### Mechanical Specifications

XFP transceivers are compliant with the dimensions defined by the XFP Multi-Sourcing Agreement (MSA).

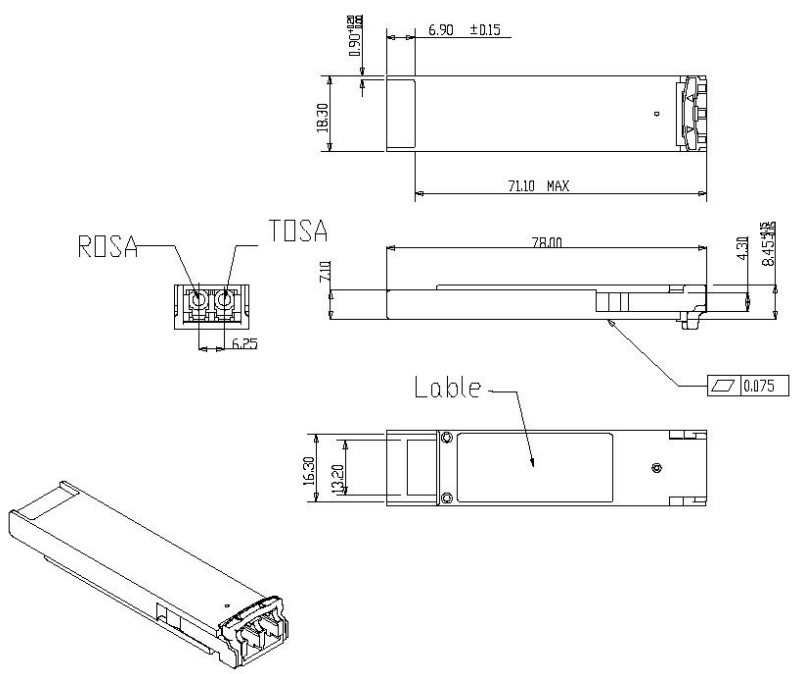

Unit:mm



**Ordering information**

Part Number	Product Description
SPT-X85TG-SR	10Gbps, XFP, 300m, 0°C ~ +70°C

Note:

- 1、 If you need -40 ~85°C products, add “T” after Part Number .
- 2、 If you need more customized services, please contact us.

E-mail: [info@sopto.com.cn](mailto:info@sopto.com.cn)

Web : <http://www.sopto.com.cn>