

SPT-P1316G-10D

16G SFP+ Transceiver LR Hot Pluggable, Duplex LC, +3.3V 1310nm DFB-LD

Features

- Up to 14.025Gb/s data links
- Hot Pluggable SFP+ footprint
- Built-in digital diagnostic functions
- 1310nm DFB laser transmitter
- Duplex LC connector
- Up to 10 km on 9/125um SMF
- Metal enclosure, for lower EMI
- Single 3.3V power supply
- Operating case temperature: 0 to 70°C
- RoHS compliant (lead free)

Applications

- Tri Rate 2.125/4.25/8.5/14.025Gbs Fiber Channel

Description

These SFP+ transceivers are designed for use in Fibre Channel links up to 14.025 Gb/s data rate over single mode fiber. They are compliant with FC-PI-5 Rev. 6.00, SFF-8472 Rev 11.0 and SFF-8081, and compatible with SFF-8432 and applicable portions of SFF-8431 Rev. 4.1. The high performance 1310nm DFB transmitter and high sensitivity PIN receiver provide superior performance for Ethernet applications at up to 10km links.

Digital diagnostics functions are available via a 2-wire serial interface, as specified in SFF-8472.

The fully SFP compliant form factor provides hot pluggability, easy optical port upgrades and low EMI emission.

Absolute Maximum Ratings

These values represent the damage threshold of the module. Stress in excess of any of the individual Absolute Maximum Ratings can cause immediate catastrophic damage to the module even if all other parameters are within Recommended Operating Conditions

Parameter	Symbol	Min.	Max.	Units
-----------	--------	------	------	-------

Storage Temperature	TS	-40		+85
Case Operating Temperature	TA	0		70
Maximum Supply Voltage	Vcc	-0.5		4
Relative Humidity	RH	0		85

Recommended Operating Conditions

Parameter	Symbol	Min	Typical	Max	Unit
Supply Voltage	Vcc	3.0	3.3	3.6	V
Supply current	Icc			220	mA
Operating Case Temperature	Tc	0	25	70	°C
Module Power Dissipation	Pm		0.7	1.1	W

Notes:

1. Supply current is shared between VCCTX and VCCR_X.
2. In-rush is defined as current level above steady state current requirements.

Electrical Characteristics (TOP = 0 to 70 °C, VCC = 3.0 to 3.60 Volts)

Parameter	Symbol	Min.	Typica	Max	Unit	Ref
Supply Voltage	Vcc	3.135		3.465	V	
Supply Current	Icc			300	mA	1
Power Consumption	P			1.5	W	
Transmitter						
Input differential	R _{in}		100		Ω	2
Differential input voltage swing	V _{in,p} p	90		800	mV	
Transmit Disable Voltage	V _D	2		Vcc	V	3
Transmit Enable Voltage	V _{EN}	V _e		V _{ee} +0.8	V	
Receiver						
Single ended data output	V _{out,pp}	185		425	mV	4
LOS Fault	V _{LOS} fault	2		Vcc _{HOST}	V	5
LOS Normal	V _{LOS} norm	V _{ee}		V _{ee} +0.8	V	5
Power Supply Rejection	PSR	100			mVpp	6

Notes:

1. With established link. The total power dissipation could exceed 1W when the module is trying to establish link at operating case temperature below 25°C
2. Connected directly to TX data input pins. AC coupling from pins into laser driver IC.

3.Or open circuit.

4.Into 100 ohms differential termination.

5.LOS is an open collector output. Should be pulled up with 4.7k – 10kohms on the host board. Normal operation is logic 0; loss of signal is logic 1. Maximum pull-up voltage is 5.5V.

7.Receiver sensitivity is compliant with power supply sinusoidal modulation of 20 Hz to 1.5 MHz up to specified value applied through the recommended power supply filtering network.

Optical Parameters(TOP = 0 to 70°C, VCC = 3.00 to 3.60 Volts)

Parameter	Symbol	Min.	Typical	Max.	Unit	Note
Transmitter Section:						
Center Wavelength	λ_t	1290	1310	1330	nm	
RMS spectral width	λ_{RMS}			0.59	nm	
Average Optical Power	P_{avg}	-4.0		-2.0	dBm	1
Optical Power OMA	4.25Gb/s	Poma	-6.1		dBm	
	8.5Gb/s		-5.2			
	14.025Gb/s		-4.8			
Optical Rise/Fall Time @ 4.25Gb/s	t_r / t_f			90	ps	2
Transmitter Waveform and Dispersion Penalty, 8.5 Gb/s	TWDP			4.3	dB	3
Vertical Eye Closure Penalty						
14.025 Gb/s	CEVPQ					
Receiver Section:						
Center Wavelength	λ_r	1270		1360	nm	
Average Receiver Power	Rx_{MAX}	0			dBm	
Receiver Stressed Sensitivity(OMA)	4.25Gb/s	Sen _{ST}		-12.0	dBm	4
	8.5Gb/s			-11.2		
	14.025Gb/s			-10.5		
Optical Return Loss		12			dB	
Los Assert	LOS _A	-30		-	dBm	
Los Dessert	LOS _D			-13	dBm	
Los Hysteresis	LOS _H	0.5			dB	

Notes:

1.Class 1 Laser Safety limit per FDA/CDRH, and EN (IEC) 60825 laser safety standards.

2.Unfiltered, 20-80%. Complies with FC 1x and 2x eye mask when filtered

3.TWDP is calculated with a 1,0 equalizer and a 9.84 GHz Gaussian filter for the fiber simulation. Jitter values at γ_T and γ_R are controlled by TWDP and stress receiver sensitivity.

4.Unstressed Rx sensitivity



Timing Characteristics

Parameter	Symbol	Min.	Typical	Max.	Unit
TX_Disable Assert Time	t_off			10	us
TX_Disable Negate Time	t_on			1	ms
Time to Initialize Include Reset of TX_FAULT	t_int			300	ms
TX_FAULT from Fault to Assertion	t_fault			100	us
TX_Disable Time to Start Reset	t_reset	10			us
Receiver Loss of Signal Assert Time	T _A ,RX_LOS			100	us
Receiver Loss of Signal Deassert Time	T _d ,RX_LOS			100	us
Rate-Select Change Time	t_ratesel			10	us
Serial ID Clock Time	t_serial-clock			100	kHz

Pin Assignment

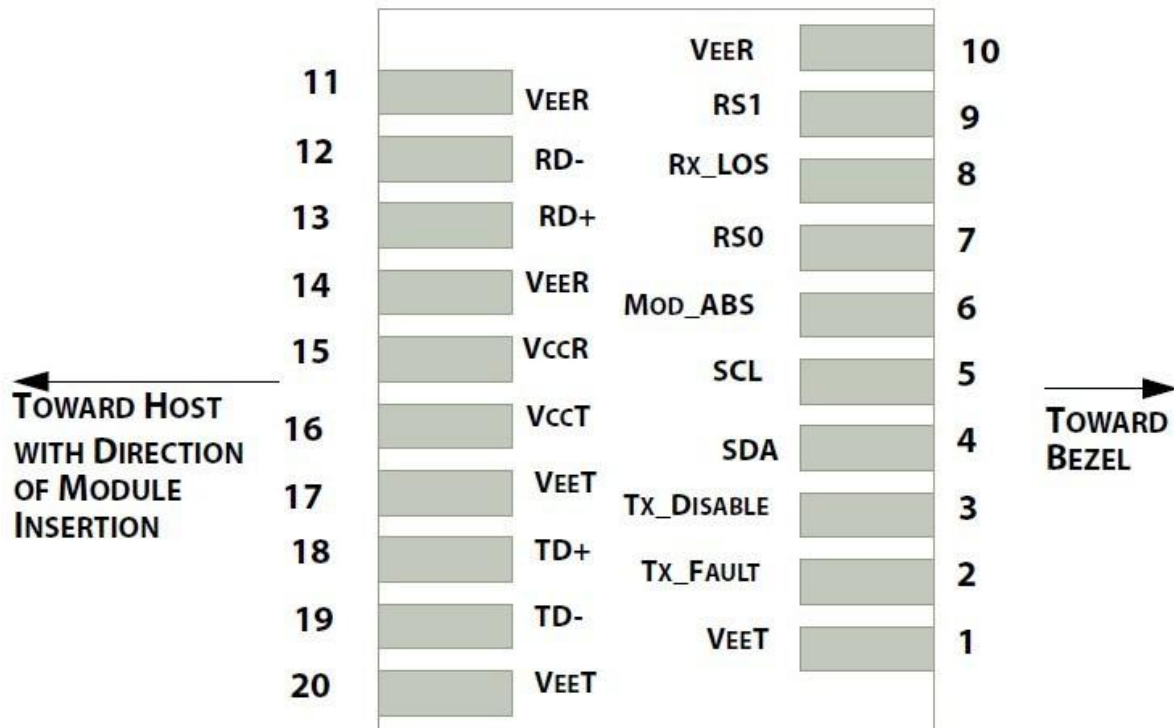

Pin Function Definitions

PIN	Symbol	Name / Description	Note
1	VEET	Transmitter Ground (Common with Receiver Ground)	1
2	T _{FAULT}	Transmitter Fault.	2
3	T _{DIS}	Transmitter Disable. Laser output disabled on high or open.	3
4	SDA	2-wire Serial Interface Data Line (MOD-DEF2)	4
5	SCA	2-wire Serial Interface Clock (MOD-DEF1)	4
6	MOD_ABS	Module Absent, connected to VEET or VEER	4
7	RS0	Receiver Rate Select	

8	LOS	Loss of Signal indication. Logic 0 indicates normal operation.	5
9	RS1	Transmitter Rate Select (not used)	
10	V _{EEER}	Receiver Ground (Common with Transmitter Ground)	1
11	V _{EEER}	Receiver Ground (Common with Transmitter Ground)	1
12	RD-	Receiver Inverted DATA out. AC Coupled	
13	RD+	Receiver Non-inverted DATA out. AC Coupled	
14	V _{EEER}	Receiver Ground (Common with Transmitter Ground)	1
15	V _{CCCR}	Receiver Power Supply	
16	V _{CCT}	Transmitter Power Supply	
17	V _{EET}	Transmitter Ground (Common with Receiver Ground)	1
18	TD+	Transmitter Non-Inverted DATA in. AC Coupled.	
19	TD-	Transmitter Inverted DATA in. AC Coupled.	
20	V _{EET}	Transmitter Ground (Common with Receiver Ground)	1

Notes:

- 1.Circuit ground is internally isolated from chassis ground.
- 2.TFAULT is an open collector/drain output, which should be pulled up with a 4.7k – 10k Ohms resistor on the host board if intended for use. Pull up voltage should be between 2.0V to V_{cc} + 0.3V. A high output indicates a transmitter fault caused by either the TX bias current or the TX output power exceeding the preset alarm thresholds. A low output indicates normal operation. In the low state, the output is pulled to <0.8V.
- 3.Laser output disabled on TDIS >2.0V or open, enabled on TDIS <0.8V.
- 4.Should be pulled up with 4.7k – 10kohms on host board to a voltage between 2.0V and 3.6V. MOD_ABS pulls line low to indicate module is plugged in.
- 5.LOS is open collector output. Should be pulled up with 4.7k – 10kohms on host board to a voltage between 2.0V and 3.6V. Logic 0 indicates normal operation; logic 1 indicates loss of signal.

SFP Module EEPROM Information and Management

The SFP modules implement the 2-wire serial communication protocol as defined in the SFP-8472. The serial ID information of the SFP modules and Digital Diagnostic Monitor parameters can be accessed through the I2C interface at address A0h and A2h. The memory is mapped in Table 1. Detailed ID information (A0h) is listed in Table 2. And the DDM specification is at address A2h. For more details of the memory map and byte definitions, please refer to the SFF-8472, “Digital Diagnostic Monitoring Interface for Optical Transceivers”. The DDM parameters have been internally calibrated. Table 1. Digital Diagnostic Memory Map (Specific Data Field Descriptions)

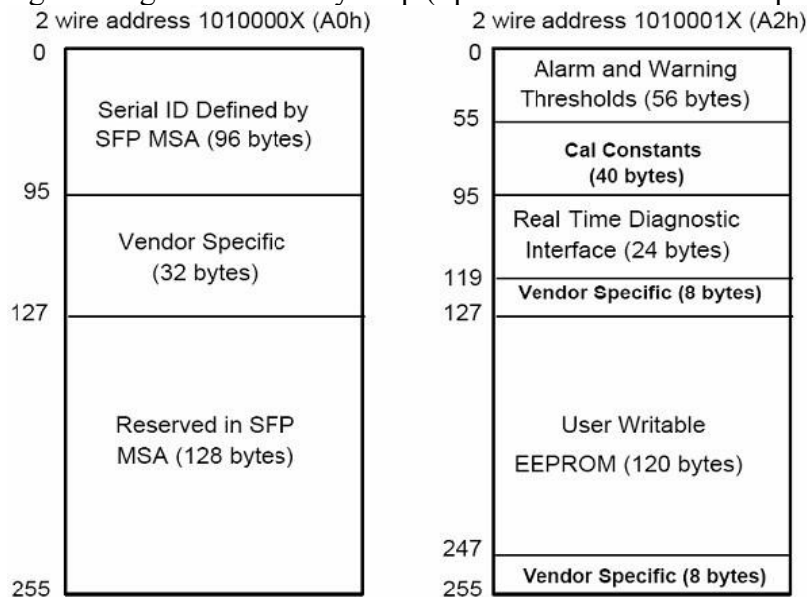



Table 2 - EEPROM Serial ID Memory Contents (A0h)

Data Address	Length (Byte)	Name of Length	Description and Contents
Base ID Fields			
0	1	Identifier	Type of Serial transceiver (03h=SFP)
1	1	Reserved	Extended identifier of type serial transceiver (04h)
2	1	Connector	Code of optical connector type (07=LC)
3-10	8	Transceiver	Fibre Channel LR Single mode
11	1	Encoding	64B/66B
12	1	BR, Nominal	Nominal baud rate, unit of 100Mbps
13-14	2	Reserved	(0000h)
15	1	Length(9um)	Link length supported for 9/125um fiber, units of 100m
16	1	Length(50um)	Link length supported for 50/125um fiber, units of 10m
17	1	Length(62.5um)	Link length supported for 62.5/125um fiber, units of 10m
18	1	Length(Copper)	Link length supported for copper, units of meters
19	1	Reserved	
20-35	16	Vendor Name	SFP vendor name: SOPTO
36	1	Reserved	
37-39	3	Vendor OUI	SFP transceiver vendor OUI ID
40-55	16	Vendor PN	Part Number in ASCII
56-59	4	Vendor rev	Revision level for part number
60-62	3	Reserved	
63	1	CCID	Least significant byte of sum of data in address 0-62
Extended ID Fields			
64-65	2	Option	Indicates which optical SFP signals are implemented (001Ah = LOS, TX_FAULT, TX_DISABLE all supported)
66	1	BR, max	Upper bit rate margin, units of %
67	1	BR, min	Lower bit rate margin, units of %
68-83	16	Vendor SN	Serial number (ASCII)
84-91	8	Date code	SOPTO's Manufacturing date code
92-94	3	Reserved	
95	1	CCEX	Check code for the extended ID Fields (addresses 64 to 94)
Vendor Specific ID Fields			
96-127	32	Readable	SOPTO specific date, read only
128-255	128	Reserved	Reserved for SFF-8079

Digital Diagnostic Specifications

These transceivers can be used in host systems that require either internally or externally calibrated digital diagnostics.

Parameter	Units	Accuracy
Transceiver temperature	°C	±5
Transceiver supply voltage	V	±3%
Transmitter bias current	mA	±10%
Transmitter output power	dBm	±3dB

Receiver average optical input power	dBm	±3dB
--------------------------------------	-----	------

Regulatory Compliance

The SFP+ complies with international Electromagnetic Compatibility (EMC) and international safety requirements and standards (see details in Table following).

Electrostatic Discharge (ESD) to the Electrical Pins	MIL-STD-883E Method 3015.7	Class 1(>1000 V)
Electrostatic Discharge (ESD) to the Duplex LC Receptacle	IEC 61000-4-2 GR-1089-CORE	Compatible with standards
Electromagnetic Interference (EMI)	FCC Part 15 Class B EN55022 Class B (CISPR 22B) VCCI Class B	Compatible with standards
Laser Eye Safety	FDA 21CFR 1040.10 and 1040.11 EN60950, EN (IEC) 60825-1,2	Compatible with Class 1 laser product.

Recommended Interface Circuit

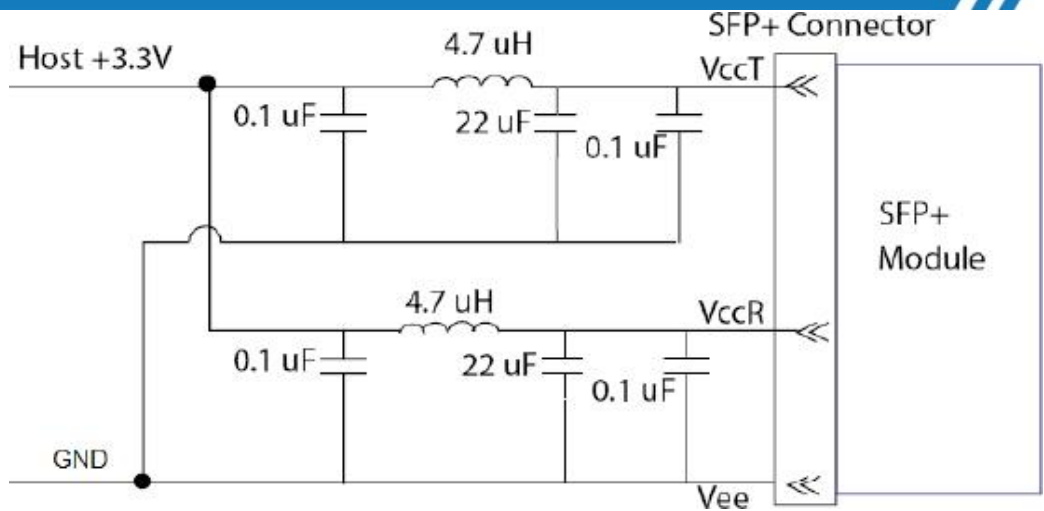

Recommended Host Board Power Supply Circuit

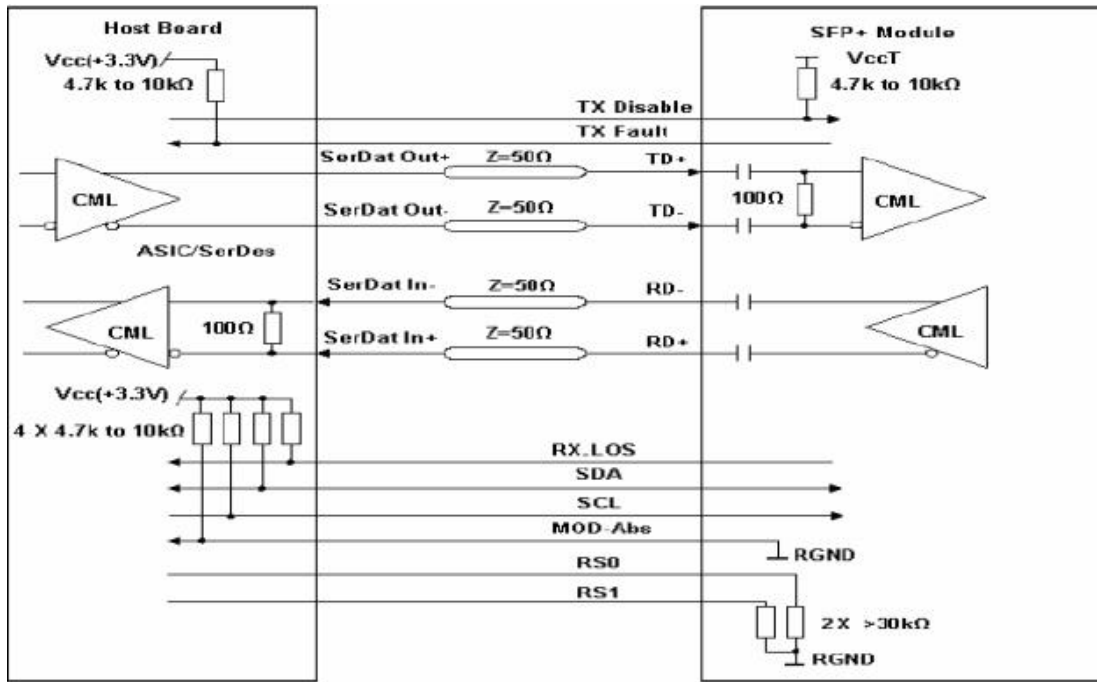

Recommended High-speed Interface Circuit

Mechanical Dimensions

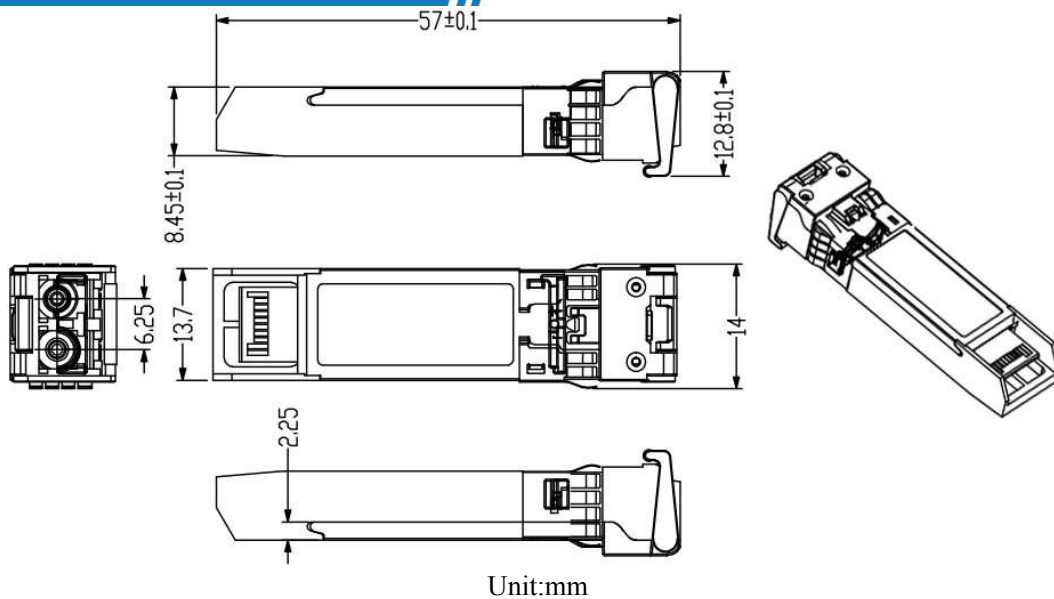

Ordering information

Part Number	Product Description
SPT-P1316G-10D	1310nm, 2.125/4.25/8.5/14.025Gbs, SFP+ 10 km, DDM, 0°C ~ +70°C

Note: If you need more customized services, please contact us.

E-mail: info@sopto.com.cn

Web : <http://www.sopto.com.cn>