

10GBPS SFP+ BI-DIRECTIONAL TRANSCEIVER,60KM REACH

1270NM TX / 1330 NM RX OR 1330NM TX / 1270 NM RX

Features

- Supports 9.95Gb/s to 10.3Gb/s data rates
- Simplex LC/SC Connector Bi-Directional SFP+ Optical Transceiver
- Single 3.3V Supply
- Up to 60km on 9/125um SMF
- 1270nm or 1330 DFB Laser transmitter,
- SFP+ MSA SFF-8431 Compliant
- Digital Diagnostic SFF-8472 Compliant
- RoHS compliant and Lead Free
- Operating case temperature: Standard: 0 ~ 70 °C

Introduction

- 10GBASE-LR at 10.3125 Gb/s
- 10GBASE-LW at 9.953 Gb/s
- Other Optical Links

Description

The series single mode transceiver is small form factor pluggable module for simplex optical data communications such as 10GBASE-ER/EW defined by IEEE 802.3ae. It is with the SFP+ 20-pin connector to allow hot plug capability.

The module is designed for single mode fiber and operates at a nominal wavelength of 1270nm or 1330nm; the transmitter section uses a multiple quantum well DFB, which is class 1 laser compliant according to International Safety Standard IEC-60825.The receiver section uses an integrated Inga As detector preamplifier (IDP) mounted in an optical header and a limiting post-amplifier IC.

Absolute Maximum Ratings

These values represent the damage threshold of the module.Stress in excess of any of the individual

Absolute Maximum Ratings can cause immediate catastrophic damage to the module even if all other parameters are within Recommended Operating Conditions.

Parameter	Symbol	Min.	Max.	Unit
Supply Voltage	V _{CC}	-0.5	+3.6	V
Storage Temperature	T _c	-40	+85	°C
Operating Case Temperature	T _c	0	+70	°C
Relative Humidity	RH	0	85	%

Recommended Operating Conditions

Parameter	Symbol	Min.	Typical	Max	Unit
Supply Voltage	V _{CC}	3.0	3.3	3.6	V
Supply Current	I _{cc}			240	mA
Operating Case Temperature	T _C	0	25	70	°C
Module Power Dissipation	P _m	-	0.7	1.1	W

[1] Supply current is shared between VCCTX and VCCR_X.

[2] In-rush is defined as current level above steady state current requirements.

Electrical Characteristics(TOP = 0 to 70° C, VCC = 3.0 to 3.60 Volts)

Parameter	Symbol	Min.	Typical	Max.	Unit	Ref.
Transmitter						
Input differential impedance	R _{in}		100		Ω	2
Single ended data input swing	V _{in,pp}	150		1200	mV _{pp}	
Transmit Disable Voltage	V _D	2		V _{CC}	V	
Transmit Enable Voltage	V _{EN}	V _{ee}		V _{ee} +0.8	V	3
Receiver						
Output differential impedance	R _{out}		100		Ω	2
Single ended data output swing	V _{out,pp}	300		700	mV	4
LOS Fault	V _{LOS fault}	2		V _{CC} _{HO} ST	V	5
LOS Normal	V _{LOS norm}	V _{ee}		V _{ee} +0.8	V	5

Note:

1. Module power consumption never exceeds 1W.
2. AC coupled.
3. Or open circuit.
4. Into 100 ohm differential termination.
5. LOS is LVTTTL. Logic 0 indicates normal operation; logic 1 indicates no signal detected.

Optical Parameters(TOP = 0 to 70° C, VCC = 3.0 to 3.60 Volts)



Parameter	Symbol	Min.	Typical	Max.	Unit	Note
Transmitter						
Optical Wavelength	λ_c	1260	1270	1280	nm	1270nm TX
		1320	1330	1340	nm	1330nm TX
Side Mode Suppress Ratio	SMSR	30			dB	
Spectral Width(-20dB)	$\Delta\lambda$			1	nm	
Average Output Power	P_{op}	1		5	dBm	1
Extinction Ratio	ER	3.5			dB	
Eye Mask	Compliant with IEEE 802.3					
Transmitter and Dispersion Penalty	TDP			3.2	dB	
Average Power of OFF Transmitter				-30	dBm	
Relative Intensity Noise	RIN			-128	dB/Hz	
Receiver						
Average Receiver Power	RSNS			-22	dBm	1,2
Receiver Overload	P_{MAX}	-7			dBm	
LOS De-Assert	LOS_D			-23	dBm	
LOS Assert	LOS_A	-33			dBm	
LOS Hysteresis		0.5		4	dB	

Note:

1. Average Receiver Power (Min) is informative and not the principal indicator of signal strength. A received power below this value cannot be compliant.
2. Measured with a PRBS2³¹-1 test pattern @10.3125Gbps, BER $\leq 10^{-12}$

Pin Descriptions

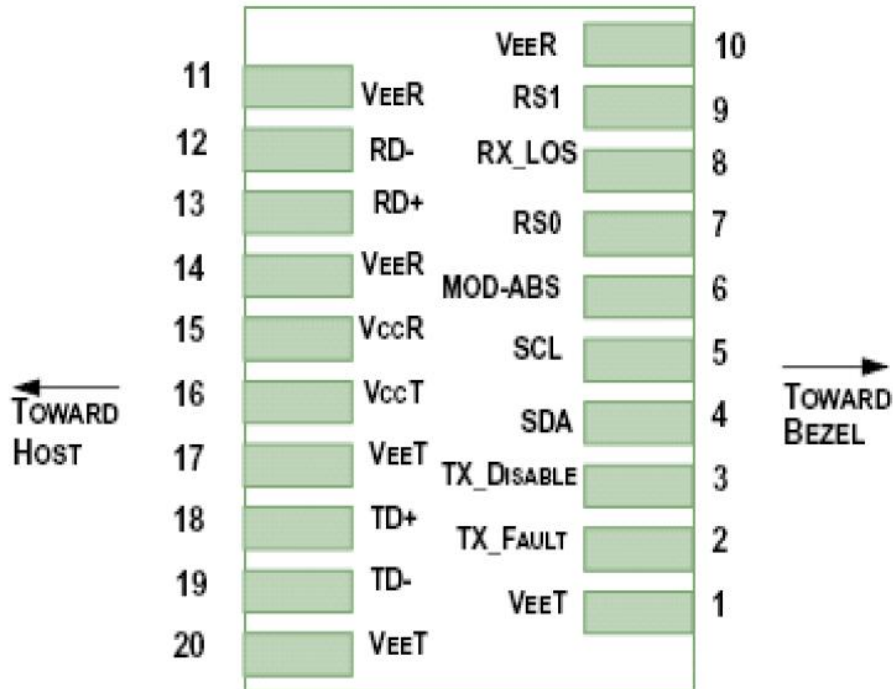

Figure1.Elecctrical Pin-out Details

Pin	Symbol	Name/Description
1	VEET [1]	Transmitter Ground
2	Tx_FAULT [2]	Transmitter Fault
3	Tx_DIS [3]	Transmitter Disable. Laser output disabled on high or open
4	SDA [2]	2-wire Serial Interface Data Line
5	SCL [2]	2-wire Serial Interface Clock Line
6	MOD_ABS [4]	Module Absent. Grounded within the module
7	RS0 [5]	RS0 for Rate Select: Open or Low = Module supports ≤4.25Gbps High = Module supports 9.95 Gb/s to 10.3125 Gb/s
8	RX_LOS [2]	Loss of Signal indication. Logic 0 indicates normal operation
9	RS1 [5]	No connection required
10	VEER [1]	Receiver Ground
11	VEER [1]	Receiver Ground
12	RD-	Receiver Inverted DATA out. AC Coupled
13	RD+	Receiver DATA out. AC Coupled
14	VEER [1]	Receiver Ground
15	VCCR	Receiver Power Supply
16	VCCT	Transmitter Power Supply
17	VEET [1]	Transmitter Ground
18	TD+	Transmitter DATA in. AC Coupled
19	TD-	Transmitter Inverted DATA in. AC Coupled

20	VEET [1]	Transmitter Ground
----	----------	--------------------

Notes:

1. Module circuit ground is isolated from module chassis ground within the module.
2. should be pulled up with 4.7k – 10k ohms on host board to a voltage between 3.15V and 3.6V.
3. Tx_Disable is an input contact with a 4.7 kΩ to 10 kΩ pullup to VccT inside the module.
4. Mod_ABS is connected to VeeT or VeeR in the SFP+ module. The host may pull this contact up to Vcc_Host with a resistor in the range 4.7 kΩ to 10 kΩ. Mod_ABS is asserted “High” when the SFP+ module is physically absent from a host slot.
5. RS0 and RS1 are module inputs and are pulled low to VeeT with > 30 kΩ resistors in the module.

Recommended Interface Circuit

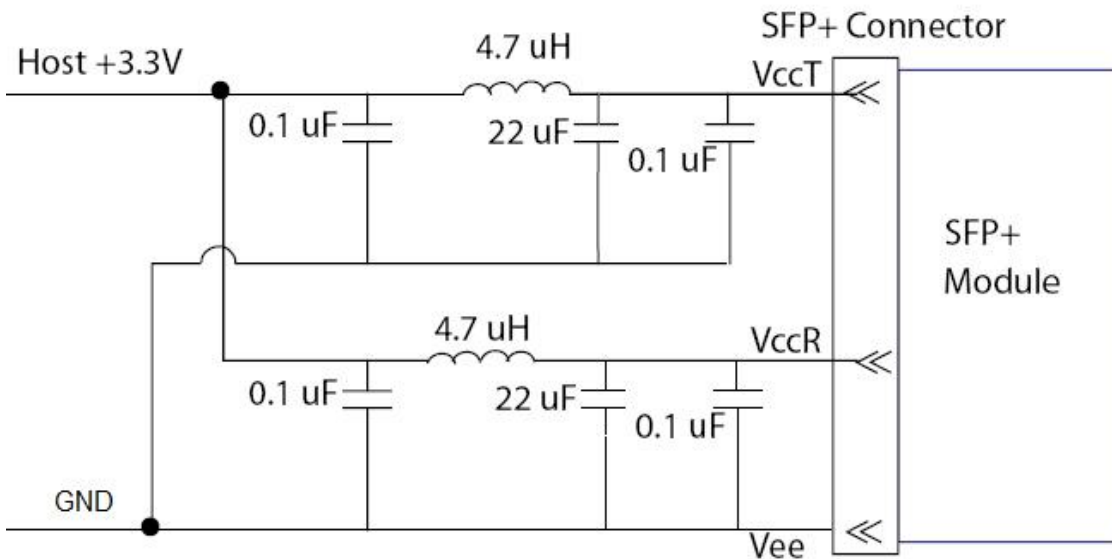

Figure2. Host Board Power Supply Filters Circuit

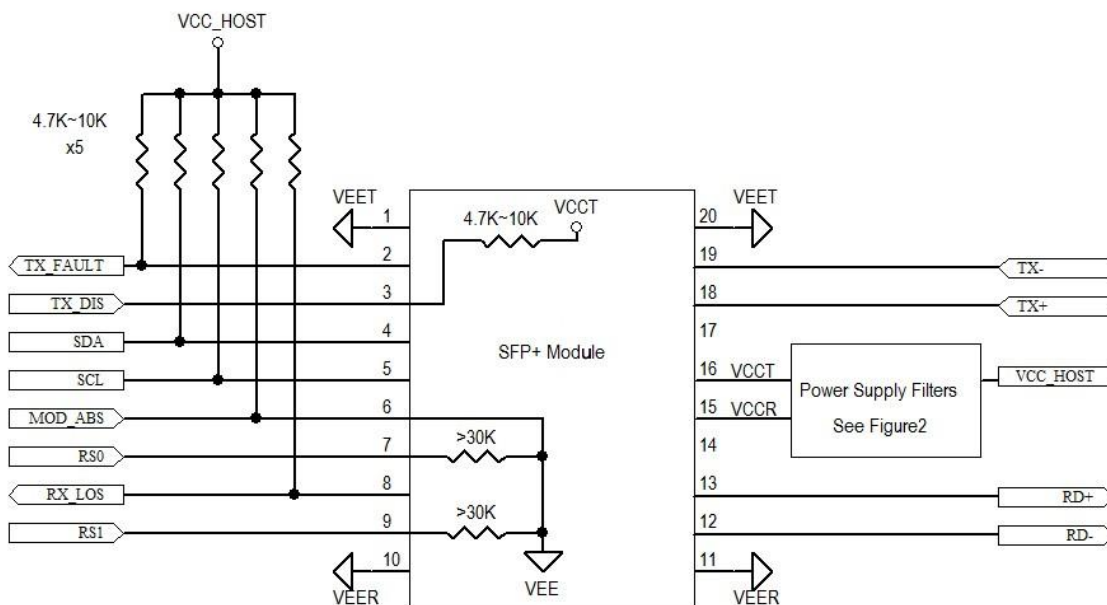
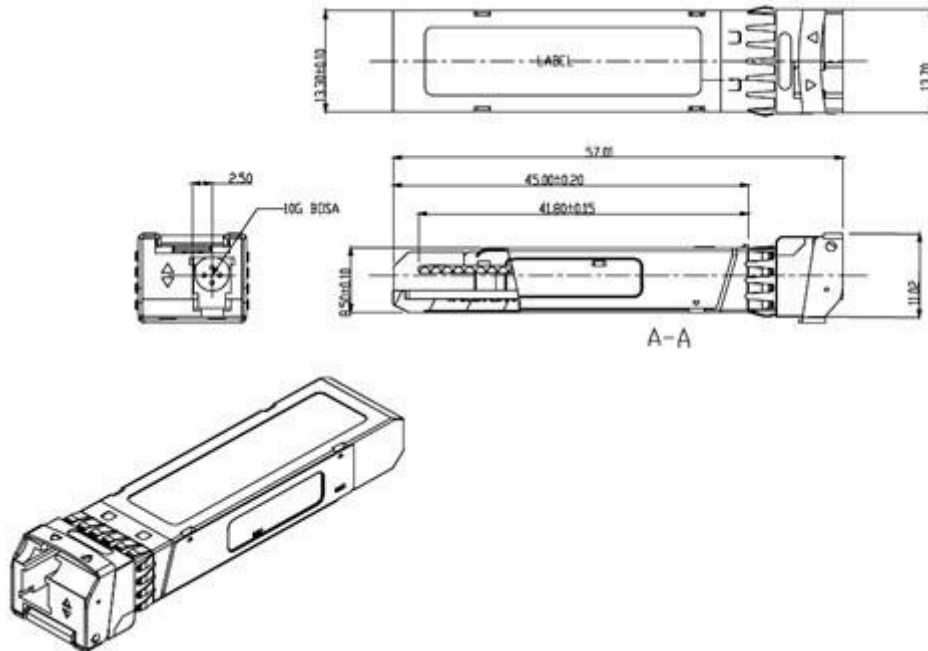

Figure3. Host-Module Interface

Mechanical Dimensions

A. LC Receptacle



B. SC Receptacle

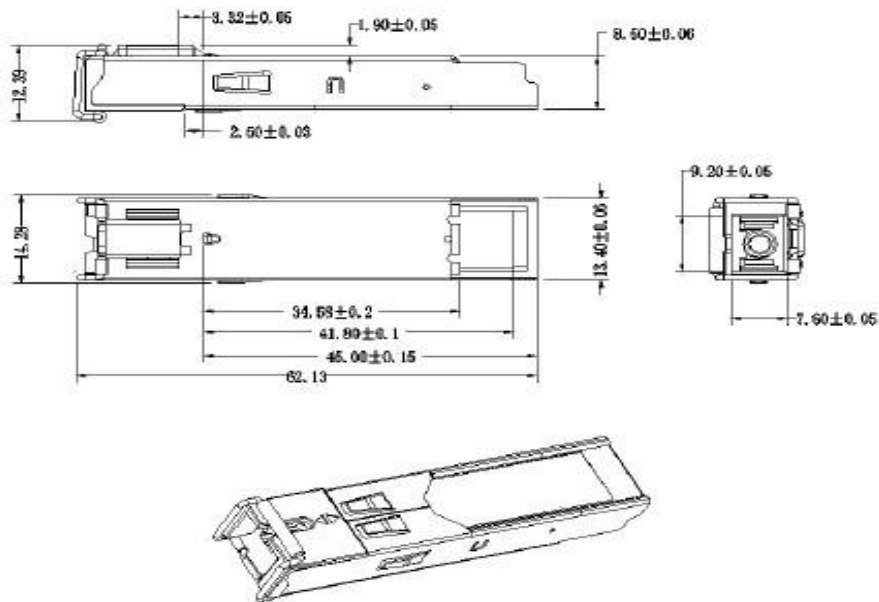

Order Information

Part Number	Product Description
SPT-PB2733TG-L60	1270nm TX/1330nm RX, 10Gbps, 60km, LC,0°C ~ +70°C, with DDM
SPT-PB3327TG-L60	1330nm TX/1270nm RX, 10Gbps, 60km, LC,0°C ~ +70°C, with DDM

Note: If you need more customized services, please contact us.

E-mail: info@sopto.com.cn

Web : <http://www.sopto.com.cn>