

# SPT-P13TG-LRT-M

## 10Gbps SFP+ Optical Transceiver, 10km or 20km Reach

### Features

- Optical interface compliant to IEEE 802.3ae 10GBASE-LR
- Electrical interface compliant to SFF-8431
- Hot Pluggable
- 1310nm DFB transmitter, PIN photo-detector
- Operating case temperature:
  - Standard: 0 to +70°C
  - Industrial: -40 to +85°C
- Low power consumption
- Applicable for 10km or 20km SMF connection
- All-metal housing for superior EMI performance
- Advanced firmware allow customer system encryption information to be stored in transceiver
- Cost effective SFP+ solution, enables higher port densities and greater bandwidth

### Applications

- 10GBASE-LR/LW Ethernet
- SONET OC-192 / SDH
- 10G Fibre Channel

### Product Description

This 1310 nm 10G SFP+ LR transceiver is a very compact 10Gb/s optical transceiver module for serial optical communication applications at 10Gb/s. The TSPLXG20D converts a 10Gb/s serial electrical data stream to 10Gb/s optical output signal and a 10Gb/s optical input signal to 10Gb/s serial electrical data streams. The high speed 10Gb/s electrical interface is fully compliant with SFI specification.

The high performance 1310nm DFB transmitter and high sensitivity PIN receiver provide superior performance for Ethernet applications at up to 10km or 20km links

The SFP+ Module compliants with SFF-8431, SFF-8432 and IEEE 802.3ae 10GBASE-LR. Digital diagnostics functions are available via a 2-wire serial interface, as specified in SFF-8472.

The fully SFP compliant form factor provides hot pluggability, easy optical port upgrades and low EMI emission.

### Absolute Maximum Ratings

These values represent the damage threshold of the module. Stress in excess of any of the individual Absolute Maximum Ratings can cause immediate catastrophic damage to the module even if all other parameters are within Recommended Operating Conditions.

Parameter	Symbol	Min.	Typical	Max.	Unit
Storage Temperature	$T_S$	-40		+85	°C
Case Operating Temperature	$T_A$	0		70	°C
Maximum Supply Voltage	$V_{CC}$	-0.5		4	V
Relative Humidity	RH	0		85	%

### Electrical Characteristics (TOP = 0 to 70 °C, VCC = 3.135 to 3.465 )

Parameter	Symbol	Min.	Typical	Max.	Unit	Note
Supply Voltage	$V_{CC}$	3.135		3.465	V	
Supply Current	$I_{CC}$			300	mA	
Power Consumption	P			1.5	W	
<b>Transmitter Section:</b>						
Input differential impedance	$R_{in}$		100		$\Omega$	1
Tx Input Single Ended DC Voltage Tolerance (Ref VeeT)	V	-0.3		4	V	
Differential input voltage swing	$V_{in,pp}$	180		700	mV	2
Transmit Disable Voltage	$V_D$	2		$V_{CC}$	V	3
Transmit Enable Voltage	$V_{EN}$	Vee		$V_{ee}+0.8$	V	
<b>Receiver Section:</b>						
Single Ended Output Voltage Tolerance	V	-0.3		4	V	
Rx Output Diff Voltage	$V_o$	500		850	mV	
Rx Output Rise and Fall Time	$T_r/T_f$	30			ps	4
LOS Fault	$V_{LOS\ fault}$	2		$V_{CC_{HOS\ T}}$	V	5
LOS Normal	$V_{LOS\ norm}$	Vee		$V_{ee}+0.8$	V	5

Note:

- 1.Connected directly to TX data input pins. AC coupling from pins into laser driver IC.
- 2.Per SFF-8431 Rev 3.0
- 3.Into 100 ohms differential termination.
- 4.20%~80%
- 5.LOS is an open collector output. Should be pulled up with 4.7k – 10k $\Omega$  on the host board. Normal operation is logic 0; loss of signal is logic 1. Maximum pull-up voltage is 5.5V.

### Optical Parameters (TOP = 0 to 70 °C, VCC = 3.135 to 3.465 )

Parameter	Symbol	Min.	Typical	Max.	Unit	Note
<b>Transmitter Section:</b>						
Center Wavelength	$\lambda_t$	1290	1310	1330	nm	
spectral width	$\Delta\lambda$			1	nm	
Average Optical Power	$P_{avg}$	-8.2		0.5	dBm	1
Optical Power OMA	$P_{oma}$	-5.2			dBm	
Laser Off Power	$P_{off}$			-30	dBm	
Extinction Ratio	ER	3.5			dB	7
Extinction Ratio	ER	6			dB	6
Transmitter Dispersion Penalty	TDP			3.2	dB	2
Relative Intensity Noise	$R_{in}$			-128	dB/Hz	3
Optical Return Loss Tolerance		20			dB	
<b>Receiver Section:</b>						
Center Wavelength	$\lambda_r$	1260		1355	nm	
Receiver Sensitivity	$S_{en}$			-14.5	dBm	4,7
Receiver Sensitivity	$S_{en}$			-14.5	dBm	4,6
Stressed Sensitivity (OMA)	$S_{enST}$			-10.3	dBm	4
Los Assert	LOSA	-25		-	dBm	
Los Dessert	LOSD			-15	dBm	
Los Hysteresis	LOSH	0.5			dB	
Overload	Sat	0			dBm	5
Receiver Reflectance	$R_{rx}$			-12	dB	

Note:

- 1.Average power figures are informative only, per IEEE802.3ae.
- 2.TWDP figure requires the host board to be SFF-8431compliant. TWDP is calculated using the Matlab code provided in clause 68.6.6.2 of IEEE802.3ae.
- 3.12dB reflection.
- 4.Conditions of stressed receiver tests per IEEE802.3ae. CSRS testing requires the host board to be SFF-8431 compliant.
- 5.Receiver overload specified in OMA and under the worst comprehensive stressed condition.
- 6.SONET OC-192 / SDH
- 7.10GBASE-LR/LW Ethernet

## Timing Characteristics

Parameter	Symbol	Min.	Typical	Max.	Unit
TX_Disable Assert Time	$t_{off}$			10	us
TX_Disable Negate Time	$t_{on}$			1	ms
Time to Initialize Include Reset of TX_FAULT	$t_{int}$			300	ms
TX_FAULT from Fault to Assertion	$t_{fault}$			100	us
TX_Disable Time to Start Reset	$t_{reset}$	10			us

Receiver Loss of Signal Assert Time	$T_{A,RX\_LOS}$			100	us
Receiver Loss of Signal Deassert Time	$T_{d,RX\_LOS}$			100	us
Rate-Select Chage Time	$t_{ratesel}$			10	us
Serial ID Clock Time	$t_{serial-clock}$			100	kHz

## Pin definition

The SFP+ modules are hot-pluggable. Hot pluggable refers to plugging in or unplugging a module while the host board is powered. The SFP+ host connector is a 0.8 mm pitch 20 position right angle improved connector specified by SFF-8083, or stacked connector with equivalent with equivalent electrical performance. Host PCB contact assignment is shown in Figure 2 and contact definitions are given in Table 2. SFP+ module contacts mates with the host in the order of ground, power, followed by signal as illustrated by Figure 3 and the contact sequence order listed in Table 2.

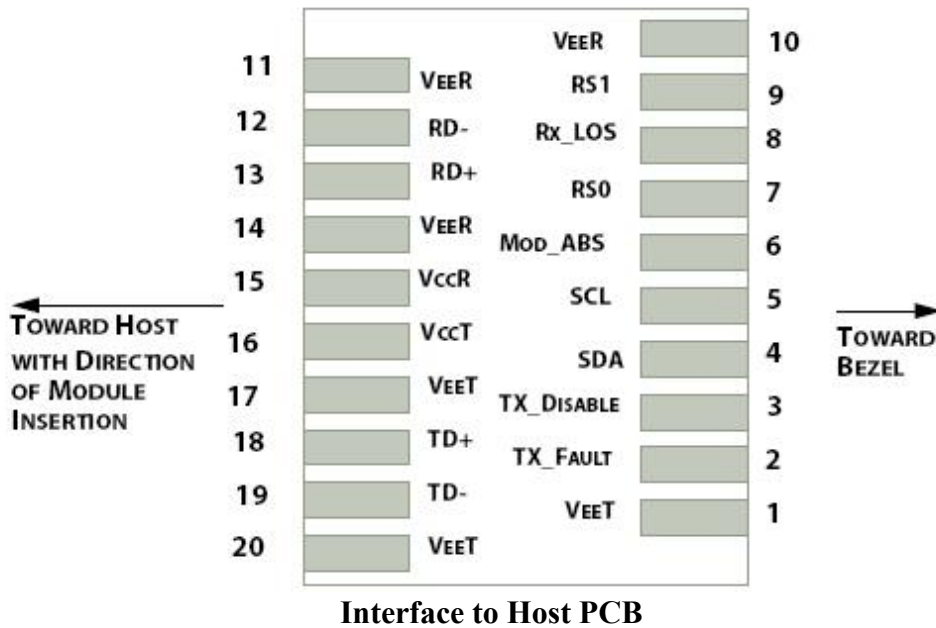

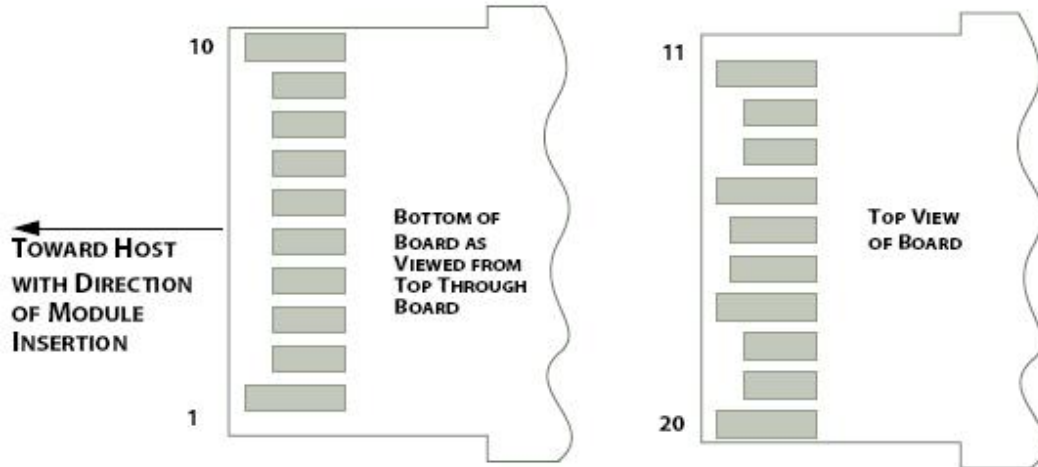

### Module Contact Assignment

Pin	Symbol	Name/Description
1	VEET [1]	Transmitter Ground
2	Tx_FAULT [2]	Transmitter Fault
3	Tx_DIS [3]	Transmitter Disable. Laser output disabled on high or open
4	SDA [2]	2-wire Serial Interface Data Line
5	SCL [2]	2-wire Serial Interface Clock Line
6	MOD_ABS [4]	Module Absent. Grounded within the module
7	RS0 [5]	RS0 for Rate Select: Open or Low = Module supports ≤4.25Gbps High = Module supports 9.95 Gb/s to 10.3125 Gb/s
8	RX_LOS [2]	Loss of Signal indication. Logic 0 indicates normal operation
9	RS1 [5]	No connection required
10	VEER [1]	Receiver Ground
11	VEER [1]	Receiver Ground
12	RD-	Receiver Inverted DATA out. AC Coupled
13	RD+	Receiver DATA out. AC Coupled
14	VEER [1]	Receiver Ground
15	VCCR	Receiver Power Supply
16	VCCT	Transmitter Power Supply
17	VEET [1]	Transmitter Ground
18	TD+	Transmitter DATA in. AC Coupled
19	TD-	Transmitter Inverted DATA in. AC Coupled
20	VEET [1]	Transmitter Ground

### SFP+ Module PIN Definition

## SFP Module EEPROM Information and Management

The SFP modules implement the 2-wire serial communication protocol as defined in the SFP -8472. The serial ID information of the SFP modules and Digital Diagnostic Monitor parameters can be accessed through the I2C interface at address A0h and A2h. The memory is mapped in Table 1. Detailed ID information (A0h) is listed in Table 2. And the DDM specification at address A2h. For more details of the memory map and byte definitions, please refer to the SFF-8472, “Digital Diagnostic Monitoring Interface for Optical Transceivers”. The DDM parameters have been internally calibrated.

**Table 1.** Digital Diagnostic Memory Map (Specific Data Field Descriptions)

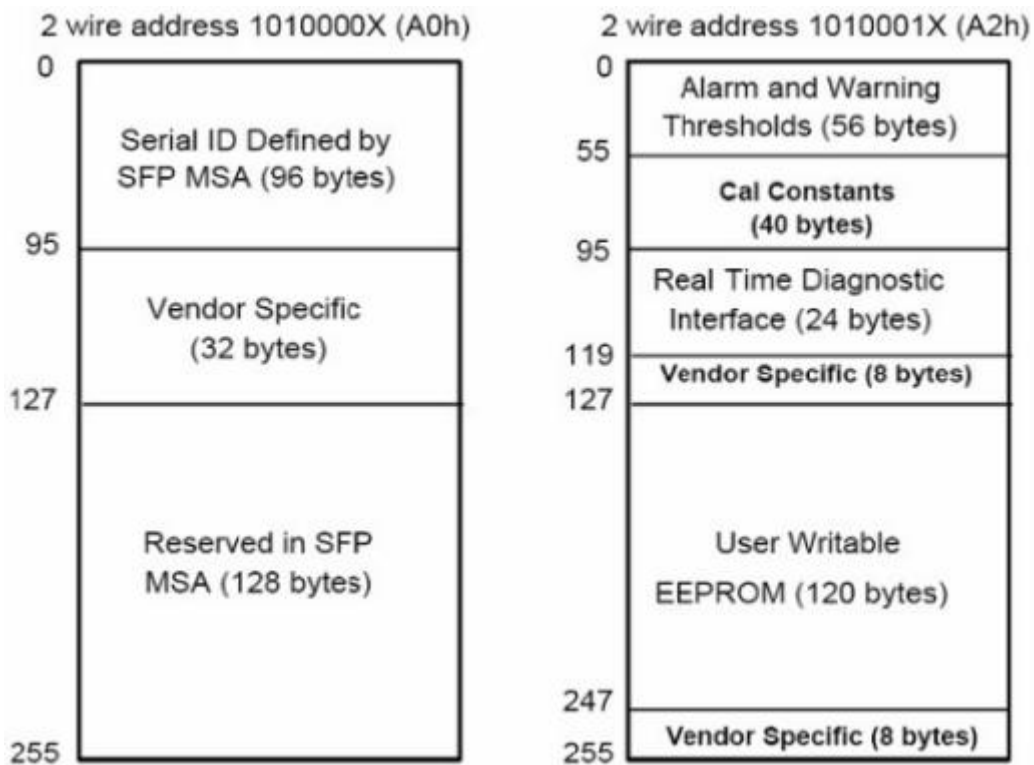

**Table 2 - EEPROM Serial ID Memory Contents (A0h)**

Data Address	Length (Byte)	Name of Length	Description and Contents
Base ID Fields			
0	1	Identifier	Type of Serial transceiver (03h=SFP)
1	1	Reserved	Extended identifier of type serial transceiver (04h)
2	1	Connector	Code of optical connector type (07=LC)
3-10	8	Transceiver	10G Base-LR
11	1	Encoding	64B/66B
12	1	BR, Nominal	Nominal baud rate, unit of 100Mbps
13-14	2	Reserved	(0000h)
15	1	Length(9um)	Link length supported for 9/125um fiber, units of 100m

16	1	Length(50um)	Link length supported for 50/125um fiber, units of 10m
17	1	Length(62.5um)	Link length supported for 62.5/125um fiber, units of 10m
18	1	Length(Copper)	Link length supported for copper, units of meters
19	1	Reserved	
20-35	16	Vendor Name	SFP vendor name: SOPTO
36	1	Reserved	
37-39	3	Vendor OUI	SFP transceiver vendor OUI ID
40-55	16	Vendor PN	Part Number: (ASCII)
56-59	4	Vendor rev	Revision level for part number
60-62	3	Reserved	
63	1	CCID	Least significant byte of sum of data in address 0-62
<b>Extended ID Fields</b>			
64-65	2	Option	Indicates which optical SFP signals are implemented (001Ah = LOS, TX_FAULT, TX_DISABLE all supported)
66	1	BR, max	Upper bit rate margin, units of %
67	1	BR, min	Lower bit rate margin, units of %
68-83	16	Vendor SN	Serial number (ASCII)
84-91	8	Date code	SOPTO's Manufacturing date code
92-94	3	Reserved	
95	1	CCEX	Check code for the extended ID Fields (addresses 64 to 94)
<b>Vendor Specific ID Fields</b>			
96-127	32	Readable	SOPTO specific date, read only
128-255	128	Reserved	Reserved for SFF-8079

### Digital Diagnostic Monitor Characteristics

Data Address	Parameter	Accuracy	Unit
96-97	Transceiver Internal Temperature	±3.0	°C
100-101	Laser Bias Current	±10	%
100-101	Tx Output Power	±3.0	dBm
100-101	Rx Input Power	±3.0	dBm
100-101	VCC3 Internal Supply Voltage	±3.0	%

### Regulatory Compliance

The SFP+ complies with international Electromagnetic Compatibility (EMC) and international safety requirements and standards (see details in Table following).

Electrostatic Discharge	MIL-STD-883E	Class 1(>1000 V)
-------------------------	--------------	------------------

(ESD) to the Electrical Pins	Method 3015.7	
Electrostatic Discharge (ESD) to the Duplex LC Receptacle	IEC 61000-4-2 GR-1089-CORE	Compatible with standards
Electromagnetic Interference (EMI)	FCC Part 15 Class B EN55022 Class B (CISPR 22B) VCCI Class B	Compatible with standards
Laser Eye Safety	FDA 21CFR 1040.10 and 1040.11 EN60950, EN (IEC) 60825-1,2	Compatible with Class 1 laser product.

### Recommended Circuit

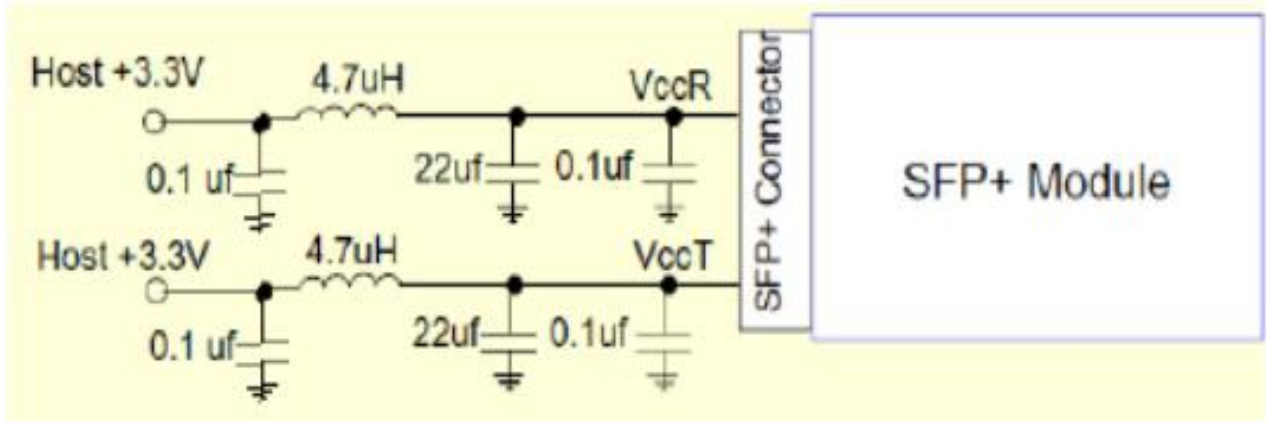

Recommended Host Board Power Supply Circuit

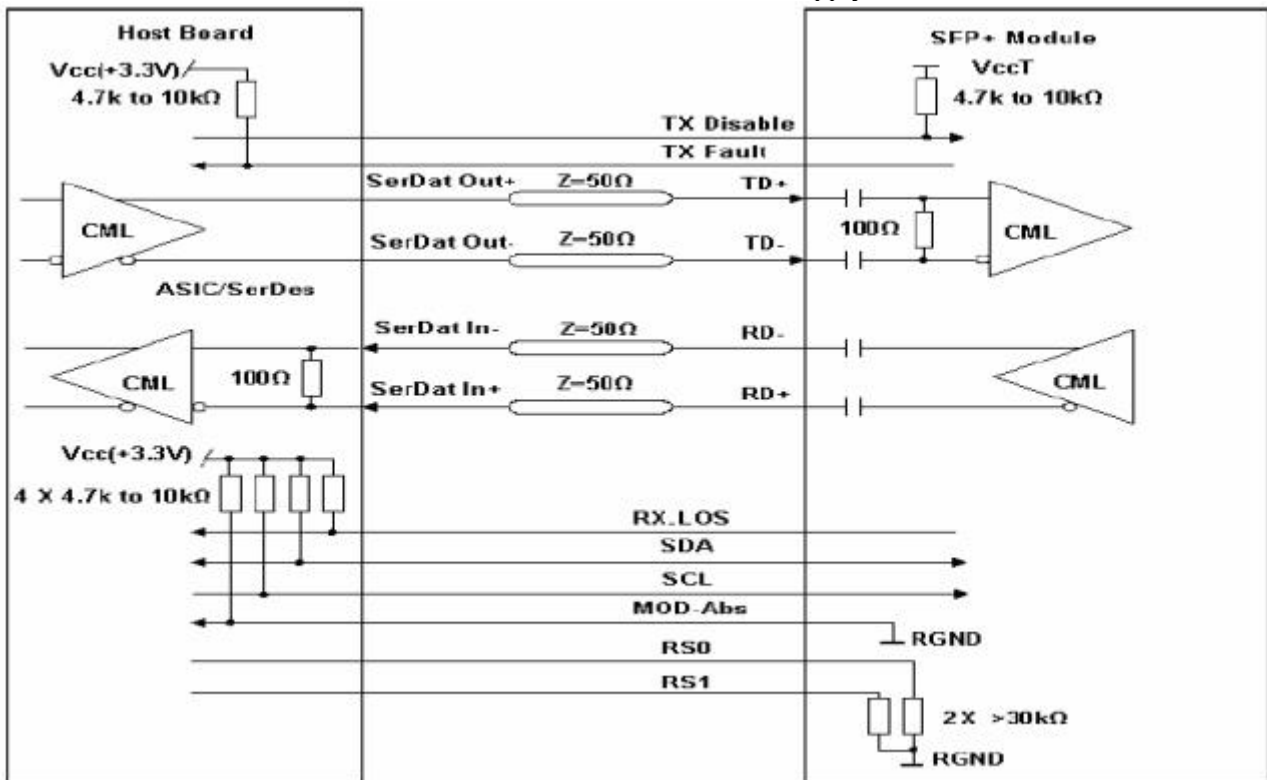

Recommended High-speed Interface Circuit



## Mechanical Dimensions

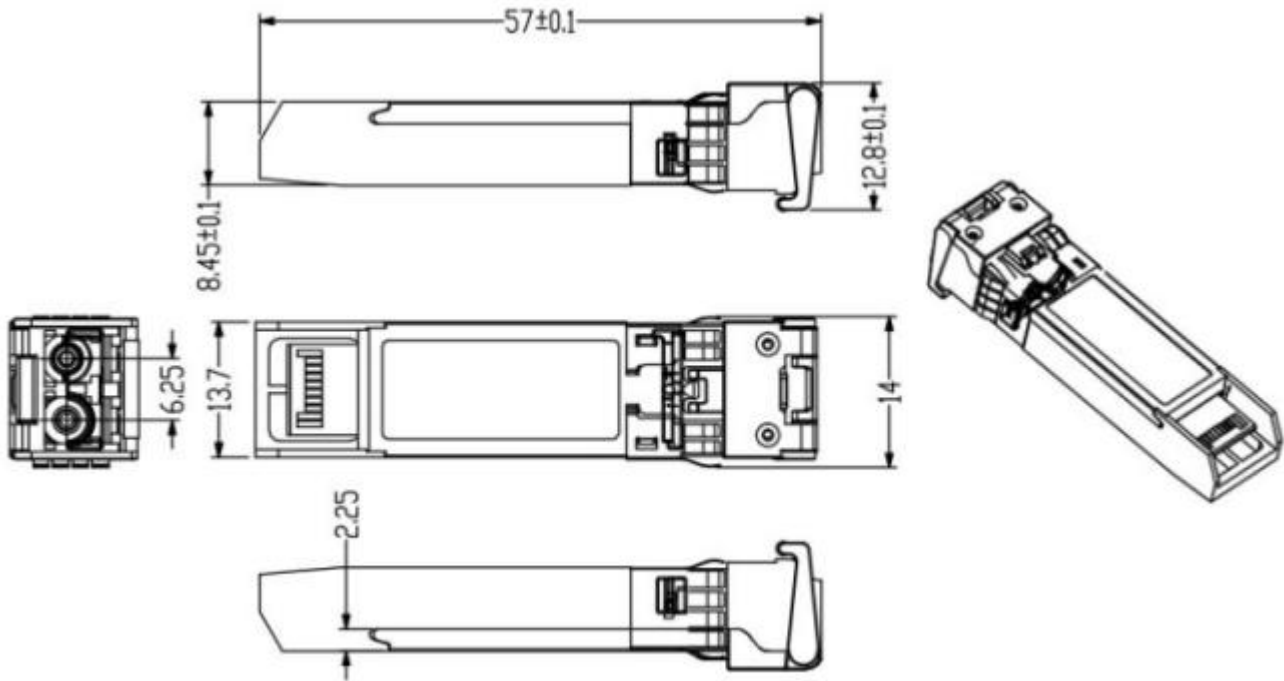

Unit:mm

## ESD

This transceiver is specified as ESD threshold 1kV for high speed pins and 2kV for all other electrical input pins, tested per MIL-STD-883, Method 3015.4 /JESD22-A114-A (HBM). However, normal ESD precautions are still required during the handling of this module. This transceiver is shipped in ESD protective packaging. It should be removed from the packaging and handled only in an ESD protected environment.

## ESD

This transceiver is specified as ESD threshold 1kV for high speed pins and 2kV for all other electrical input pins, tested per MIL-STD-883, Method 3015.4 /JESD22-A114-A (HBM). However, normal ESD precautions are still required during the handling of this module. This transceiver is shipped in ESD protective packaging. It should be removed from the packaging and handled only in an ESD protected environment.

## Ordering information

Part Number	Product Description
SPT-P13TG-LRT-M	Transceiver SFP+ 1310nm 10G 10km LC Interface with DDM Industrial Temperature (Rx Output Diff Votage 500-850mV)

Note: If you need more customized services, please contact us.

E-mail: [info@sopto.com.cn](mailto:info@sopto.com.cn)

Web : <http://www.sopto.com.cn>