

# SPT-P138G-40D

## 8.5Gb/s SFP+ Fiber Channel Optical Transceiver

### Features

- Up to 8.5Gb/s data links
- Hot Pluggable SFP+ footprint
- Built-in digital diagnostic functions
- 1310nm DFB laser transmitter
- Duplex LC connector
- Up to 40 km on 9/125um SMF
- Single 3.3V power supply
- Operating case temperature: 0 to 70°C
- RoHS compliant (lead free)

### Applications

- Tri Rate 2.125/4.25/8.5Gbs Fiber Channel

### Description

These SFP transceivers designed for use in Fiber Channel links up to 8.5 Gb/s data rate and up to 40 km link length. They are compliant with FCPI-4 Rev. 8.00 and SFF-8472 Rev 10.2, and Compatible with SFF-8432 and applicable portions of SFF-8431 Rev. The Digital Diagnostics functions are available via a 2-wire serial interface, as specified in SFF-8472, which allows Real-time access to device operating parameters such as transceiver temperature, laser bias current, Transmitted optical power, received optical power and transceiver supply voltage. 3.0. The product is RoHS Compliant and lead-free per Directive 2002/95/EC.

### Absolute Maximum Ratings

These values represent the damage threshold of the module. Stress in excess of any of the individual Absolute Maximum Ratings can cause immediate catastrophic damage to the module even if all other parameters are within Recommended Operating Conditions

Parameter	Symbol	Min.	Max.	Units
Supply Voltage	Vcc	0	+3.8	V
Storage Temperature	Tc	-40	+85	C
Operating Case Temperature	Tc	0	+70	C

Relative Humidity	RH	0	85	%
-------------------	----	---	----	---

### Recommended Operating Conditions

Parameter	Symbol	Min	Typical	Max	Unit
Supply Voltage	Vcc	3.0	3.3	3.6	V
Supply current	Icc			220	mA
Operating Case Temperature	Tc	0	25	70	°C
Module Power Dissipation	Pm		0.7	1.1	W

Notes:

1. Supply current is shared between VCCTX and VCCR<sub>X</sub>.
2. In-rush is defined as current level above steady state current requirements.

### LOW Speed Characteristics

Parameter	Symbol	Min	Typical	Max	Unit
Power Consumption				1	W
TX_ Fault, RX_LOS	VOL	0		0.4	V
	VOH	Host_Vcc-0.5		Host_Vcc+0.3	V
TX-DIS	VIL	-0.3		0.8	V
	VIH	2.0		VCCT+0.3	V
RS0,RS1	VIL	-0.3		0.8	V
	VIH	2.0		VCCT+0.3	V

### Optical Characteristics

Parameter	Symbol	Min.	Typical	Max	Unit	Ref
<b>Transmitter</b>						
Output Opt. Power,8.5 Gb/s	PO	0		3	dBm	1
Optical Wavelength	$\lambda$	1285	-	1345	nm	2
Side Mode Suppression Ratio	SMSR <sub>min</sub>	30	-		dB	2
Optical Modulation Amplitude	OMA	290	-		uW	2,3
Transmitter and Dispersion Penalty, 8.5Gb/s	TDP			3.2	dB	4
<b>Receiver</b>						
Unstressed Receiver OMA Sensitivity,8.5 Gb/s	RSENS <sub>r</sub>			0.042	mW	5
Average Received Power		-17		0	dBm	

Return Loss		12			dB	
LOS De-Assert	LOSD			-18	dBm	
LOS Assert	LOSA	-28	-		dBm	
LOS Hysteresis		0.5-	-		dB	

**Notes:**

1. High Bandwidth Mode. Class 1 Laser Safety per FDA/CDRH and EN (IEC) 60825 regulations.
2. Also specified to meet curves in FC-PI-4 Rev 8.001 Figures 21, 22, and 23, which allow trade-off between Wavelength, spectral width and OMA.
3. Equivalent extinction ratio specification for Fiber Channel. Allows smaller ER at higher average power.
4. For 8.5 Gb/s operation, Jitter values for gamma T and gamma R are controlled by TDP and stressed receiver sensitivity.
5. Measured with conformance signals defined in FC-PI-4 Rev. 8.00 specifications. Value in OMA. Measured with PRBS 2<sup>7</sup>-1 at 10<sup>-12</sup> BER.

### Electrical Characteristics

Parameter	Symbol	Min.	Typical	Max	Unit	Ref
Supply Voltage	Vcc	3.00		3.60	V	1
Supply Voltage	Icc			220	mA	1
<b>Transmitter</b>						
Input differential impedance	Rin		100		Ω	2
Single ended data input swing	V <sub>in,pp</sub>	150	-	900	mV	
Transmit Disable Voltage	VD	2	-	VCC	V	
Transmit Enable Voltage	VEN	Vee	-	Vee+0.8	V	3
<b>Receiver</b>						
Single ended data output swing	V <sub>out, pp</sub>	300		800	mV	4
Data output rise/fall time, 8.5 Gb/s	Tr, tf			60	ps	5
LOS Fault	V <sub>LOS fault</sub>	2		VCCHOST	V	6
LOS Normal	V <sub>LOS norm</sub>	Vee		Vee+0.8	V	6

**Notes:**

1. Module power consumption never exceeds 1W.
2. AC coupled.
3. Or open circuit.
4. Into 100 ohm differential termination.
5. 20 – 80 %.
6. LOS is LVTTTL. Logic 0 indicates normal operation; logic 1 indicates no signal detected.

### General Specifications

Parameter	Symbol	Min.	Typical	Max	Unit	Ref
Data Rate	DR	2.125		8.5	Gb/s	1
Bit Error Rate	BER			10 <sup>-12</sup>		2

Max. Supported Link Length on 9/125 μm SMF	L		40		Km	3
--	---	--	----	--	----	---

Notes:

1. 2x/4x/8x Fiber Channel compliant.
2. Tested with a PRBS 2<sup>7</sup>-1 test pattern.
3. Distances are based on FC-PI-4 Rev. 8.00<sup>1</sup> and IEEE 802.3 standards

### Digital Diagnostic Memory Map

The transceivers provide serial ID memory contents and diagnostic information about the present operating conditions by the 2-wire serial interface (SCL, SDA).

The diagnostic information with internal calibration or external calibration all are implemented, including received power monitoring, transmitted power monitoring, bias current monitoring, supply voltage monitoring and temperature monitoring.

The digital diagnostic memory map specific data field defines as following.

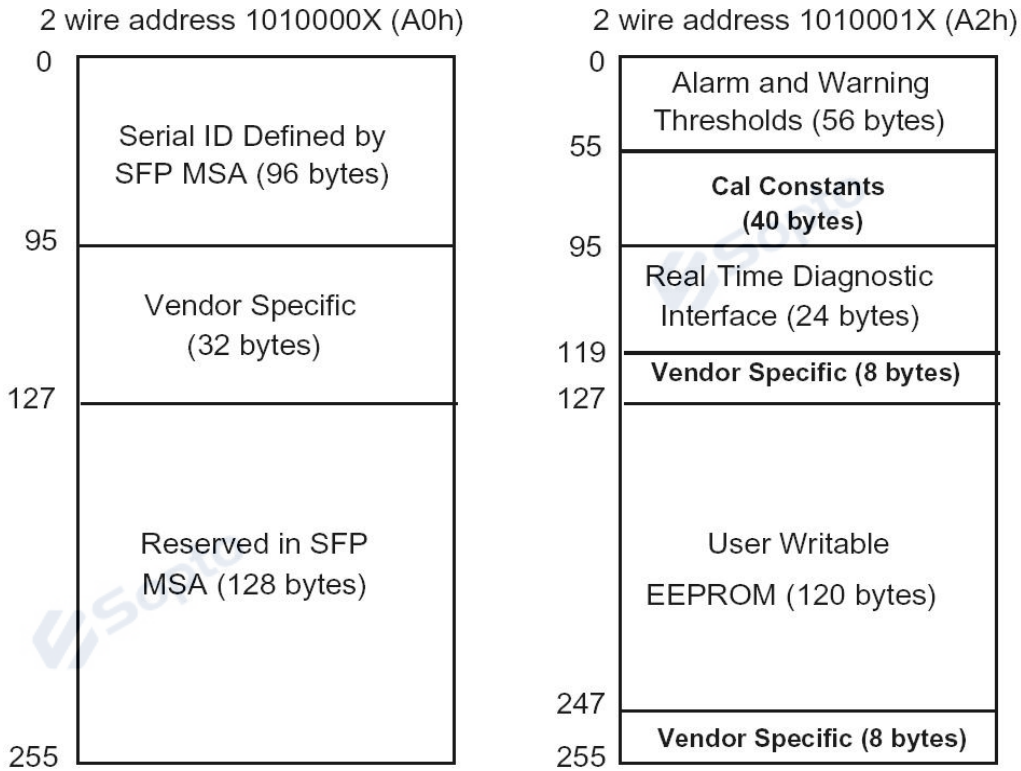

### Pin Definitions

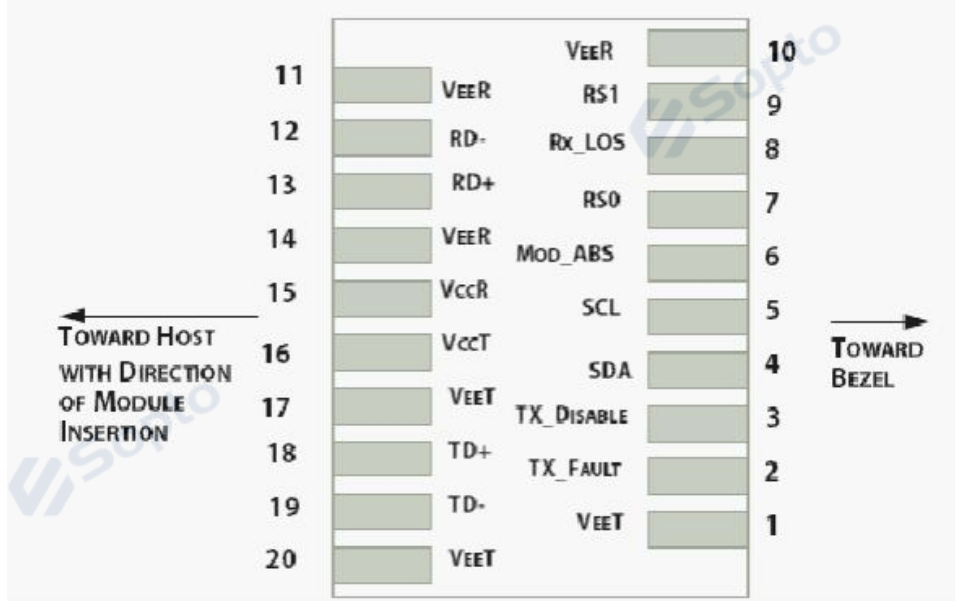

Figure 1: Interface to Host PCB

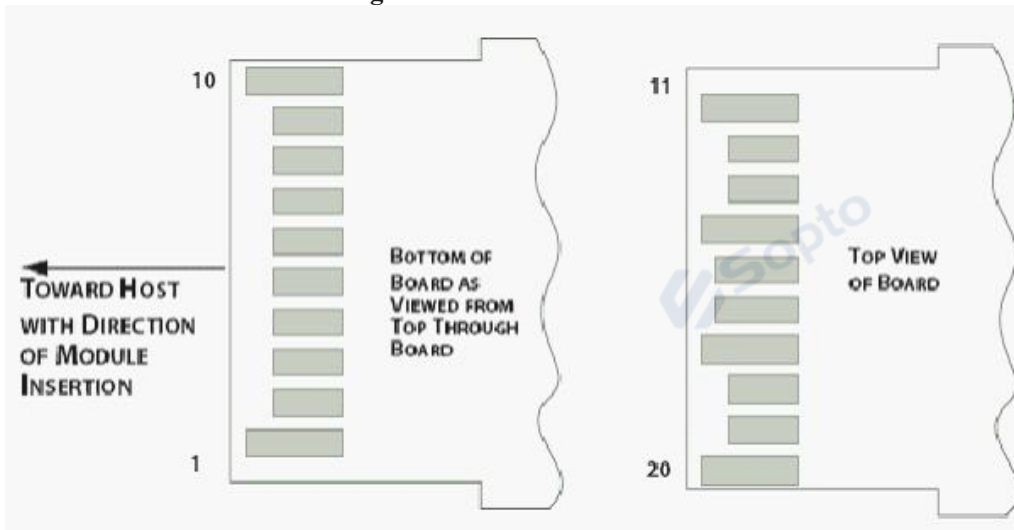

Figure 2: Module Contact Assignment

### Pin Definition

Pin	Symbol	Name/Description
1	VEET [1]	Transmitter Ground
2	Tx_FAULT [2]	Transmitter Fault
3	Tx_DIS [3]	Transmitter Disable. Laser output disabled on high or open
4	SDA [2]	2-wire Serial Interface Data Line
5	SCL [2]	2-wire Serial Interface Clock Line
6	MOD_ABS [4]	Module Absent. Grounded within the module
7	RS0 [5]	Rate Select0
8	RX_LOS [2]	Loss of Signal indication. Logic 0 indicates normal operation
9	RS1 [5]	Rate Select1

10	VEER [1]	Receiver Ground
11	VEER [1]	Receiver Ground
12	RD-	Receiver Inverted DATA out. AC Coupled
13	RD+	Receiver DATA out. AC Coupled
14	VEER [1]	Receiver Ground
15	VCCR	Receiver Power Supply
16	VCCT	Transmitter Power Supply
17	VEET [1]	Transmitter Ground
18	TD+	Transmitter DATA in. AC Coupled
19	TD-	Transmitter Inverted DATA in. AC Coupled
20	VEET [1]	Transmitter Ground

Notes:

- [1] Module circuit ground is isolated from module chassis ground within the module.
- [2].should be pulled up with 4.7k – 10k ohms on host board to a voltage between 3.15V and 3.6V.
- [3]Tx\_Disable is an input contact with a 4.7 kΩ to 10 kΩ pull-up to Vcc T inside the module.
- [4]Mod\_ABS is connected to VeeT or VeeR in the SFP+ module. The host may pull this contact up to Vcc\_Host with a resistor in the range 4.7 kΩ to 10 kΩ. Mod\_ABS is asserted “High” when the SFP+ module is physically absent from a host slot.
- [5] RS0 and RS1 are module inputs and are pulled low to VeeT with > 30 kΩ resistors in the module.

### Recommended Interface Circuit

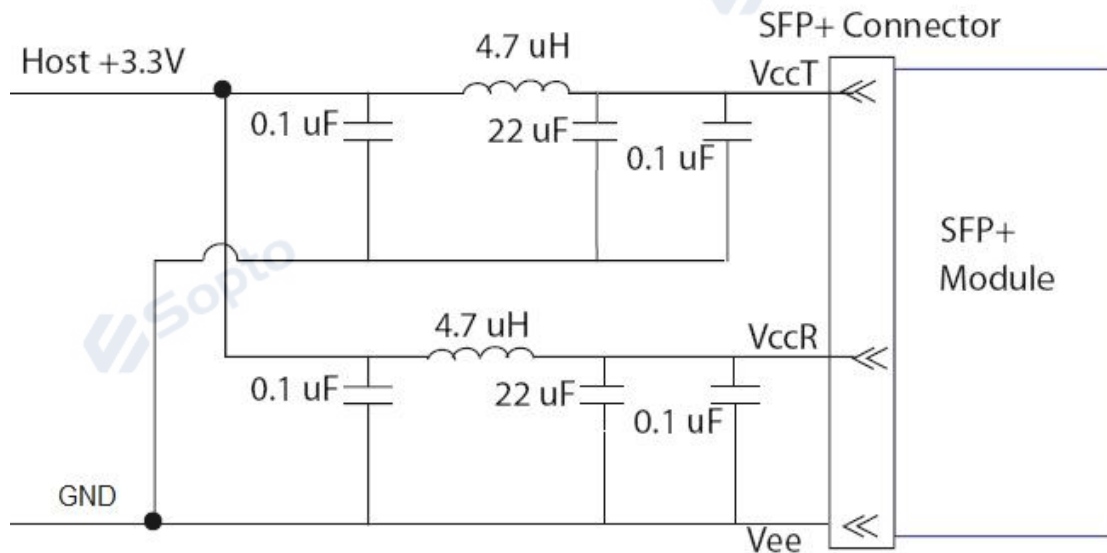

Figure3. Host Board Power Supply Filters Circuit

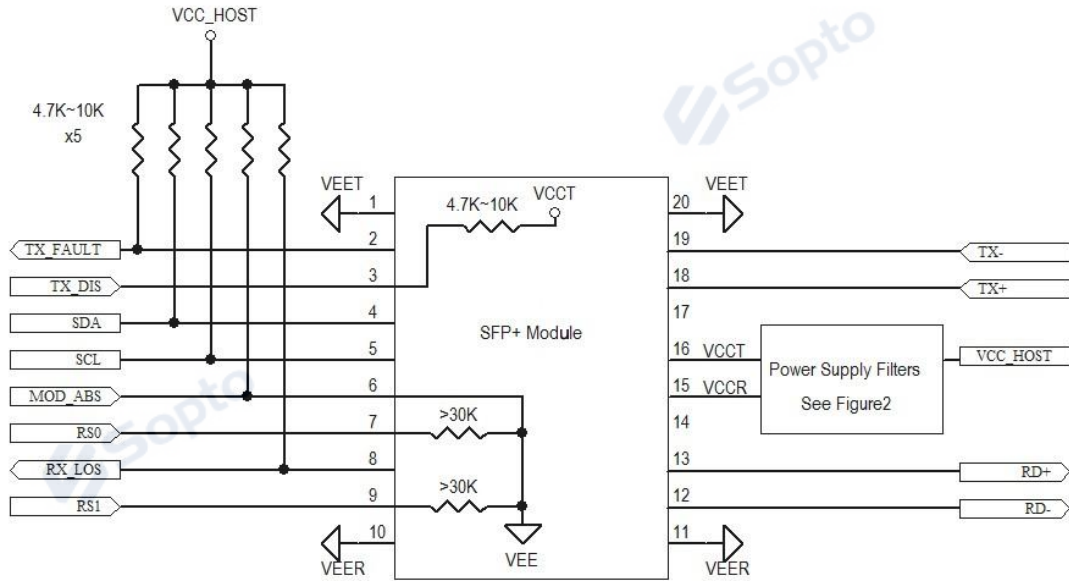
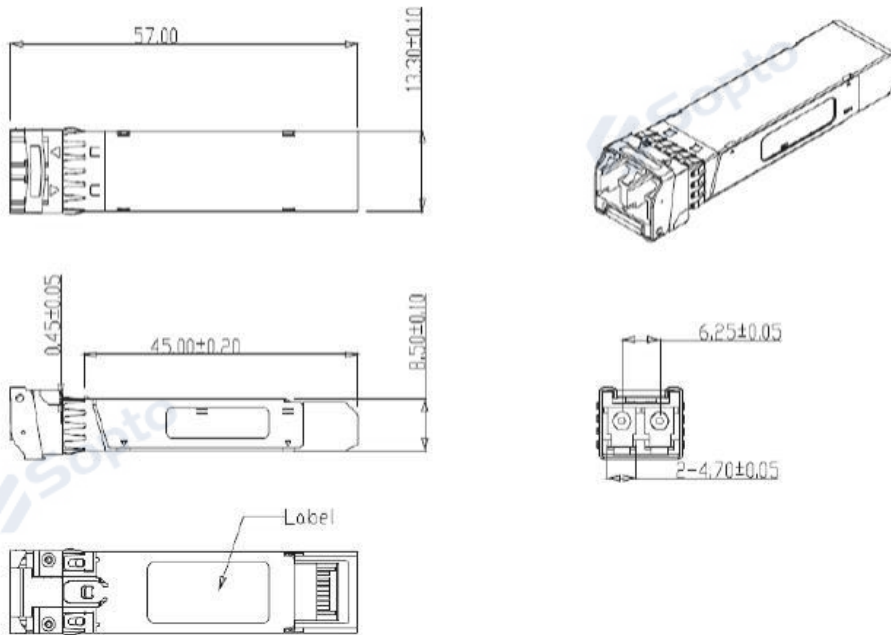

Figure4. Host-Module Interface

### Mechanical Dimensions



Unit:mm

### Ordering information

Part Number	Product Description
SPT-P138G-40D	1310nm, 2.125/4.25/8.5Gbs, SFP+ 40 km, DDM, 0°C ~ +70°C

Note: If you need more customized services, please contact us.

E-mail: [info@sopto.com.cn](mailto:info@sopto.com.cn)

Web : <http://www.sopto.com.cn>