

SPT-P854G-S3D

4.25Gbps SFP Optical Transceiver, 300m Reach

Features

- Maximum link length of 300m on 2000MHz/km MMF
- Supports 1.0625/2.125/4.25Gb/s Fiber Channel Operation
- Gigabit Ethernet compatible
- 850nm VCSEL laser transmitter
- SFP MSA SFF-8074i compliant
- Single 3.3 V supply
- Digital Diagnostic SFF-8472 compliant
- Compatible with RoHS
- Operating case temperature:

Standard: 0 to +70°C

Industrial: -40 to +85°C

Applications

- Tri Rate 1.0625 / 2.125 / 4.25Gbp/s Fiber Channel
- 1000Base-SX Ethernet
- SONET / SDH Equipment Interconnect
- Storage Area Network(SAN)
- Other Optical Link

Description

The transceiver consists of three sections: an 850nm VCSEL laser transmitter, a PIN photodiode integrated with a trans-impedance preamplifier (TIA) and MCU control unit. All modules satisfy class I laser safety requirements.

The transceivers are compatible with the Small Form Factor Pluggable Multi-Sourcing Agreement (MSA) 1. They are compatible with Fiber Channel per FC-PI-2 Rev. 10.0.also simultaneously compatible with Gigabit Ethernet as specified in IEEE Std 802.3.

Module Block Diagram

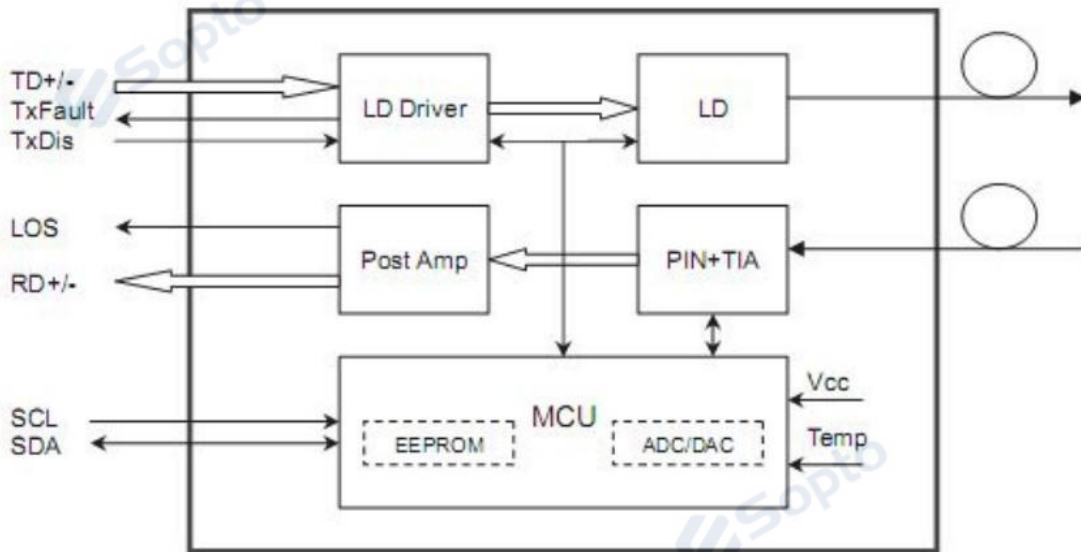

Absolute Maximum Ratings

Parameter	Symbol	Min.	Max.	Units	Notes
Storage Temperature	Tst	-40	+85	°C	-
Operating Case Temperature	Tc	0	+70	°C	Standard
		-40	+85		Industrial
Operating Humidity	RH	5	90	%	Non-condensing
Power Supply Voltage	Vcc-Vee	0	3.6	V	-

Recommended Operating Conditions

Parameter	Symbol	Min	Typical	Max	Unit
Operating Case Temperature	Standard	0		+70	°C
	Industrial	-40		+85	°C
Power Supply Voltage	Vcc	3.13	3.3	3.47	V
Power Supply Current	Icc			240	mA

Optical Characteristics

The following optical characteristics are defined over the Recommended Operating Environment

unless otherwise specified.

Parameter	Symbol	Min.	Typical	Max	Unit	Notes
Transmitter						
Center Wavelength	λ_t	840	850	860	nm	
RMS spectral width	Pm	-	-	4	nm	
Average Optical Power	Pavg	-5	-	-1	dBm	2
Extinction Ratio	ER	3	-	-	dB	3
Transmitter Dispersion Penalty	TDP	-	-	3.9	dB	
Relative Intensity Noise	Rin	-	-	-128	dB/Hz	12dB reflection
Optical Return Loss Tolerance		-	-	12	dB	
Receiver						
Center Wavelength	λ_r	840	850	860	nm	
Receiver Sensitivity	Psens	-	-	-11	dBm	4
Stressed Sensitivity in OMA		-	-	-8	dBm	4
Los function	Los	-30	-	-12	dBm	
Overload	Pin	-	-	0	dBm	4
Receiver Reflectance		-	-	-12	dB	
LOS De-Assert	LOSD			-13	dBm	
LOS Assert	LOSA	-23			dBm	

Notes:

1. Trade-offs are available between spectral width, center wavelength and minimum OMA, as shown in table 6.
2. The optical power is launched into MMF
3. Measured with a PRBS 2³¹-1 test pattern @4.25Gbps
4. Measured with a PRBS 2³¹-1 test pattern @4.25Gbps, BER ≤ 10⁻¹².

Electrical Characteristics

The following electrical characteristics are defined over the Recommended Operating Environment unless otherwise specified.

Parameter	Symbol	Min.	Typical	Max	Unit	Notes
Data Rate		-	10.3125	-	Gbps	
Power Consumption		-	600	800	mW	
Transmitter						

Single Ended Output Voltage Tolerance		-0.3	-	4.0	V	
C common mode voltage tolerance		15	-	-	mV	
Tx Input Diff Voltage	VI	180		1200	mV	
Tx Fault	VoL	-0.3		0.4	V	At 0.7mA
Data Dependent Input Jitter	DDJ			0.10	UI	
Data Input Total Jitter	TJ			0.28	UI	
Receiver						
Single Ended Output Voltage Tolerance		-0.3	-	4.0	V	
Rx Output Diff Voltage	Vo	300		850	mV	
Rx Output Rise and Fall Time	Tr/Tf	30			ps	20% to 80%
Total Jitter	TJ			0.70	UI	
Deterministic Jitter	DJ			0.42	UI	

Timing and Electrical

Parameter	Symbol	Min	Typical	Max	Unit
Tx Disable Negate Time	t _{on}			1	ms
Tx Disable Assert Time	t _{off}			10	μs
Time To Initialize, including Reset of Tx Fault	t _{init}			300	ms
Tx Fault Assert Time	t _{fault}			100	μs
Tx Disable To Reset	t _{reset}	10			μs
LOS Assert Time	t _{loss_on}			100	μs
LOS De-assert Time	t _{loss_off}			100	μs
Serial ID Clock Rate	f _{serial_clock}			400	KHz
MOD_DEF (0:2)-High	V _H	2		V _{cc}	V
MOD_DEF (0:2)-Low	V _L			0.8	V

Diagnostics

Parameter	Range	Unit	Accuracy	Calibration
Temperature	0 to +70	°C	±3°C	Internal / External
	-40 to +85			

Voltage	3.0 to 3.6	V	±3%	Internal / External
Bias Current	0 to 100	mA	±10%	Internal / External
TX Power	-5 to -1	dBm	±3dB	Internal / External
RX Power	-23 to 0	dBm	±3dB	Internal / External

Digital Diagnostic Map

The transceivers provide serial ID memory contents and diagnostic information about the present operating conditions by the 2-wire serial interface (SCL, SDA).

The diagnostic information with internal calibration or external calibration all are implemented, including received power monitoring, transmitted power monitoring, bias current monitoring, supply voltage monitoring and temperature monitoring.

The digital diagnostic memory map specific data field defines as following.

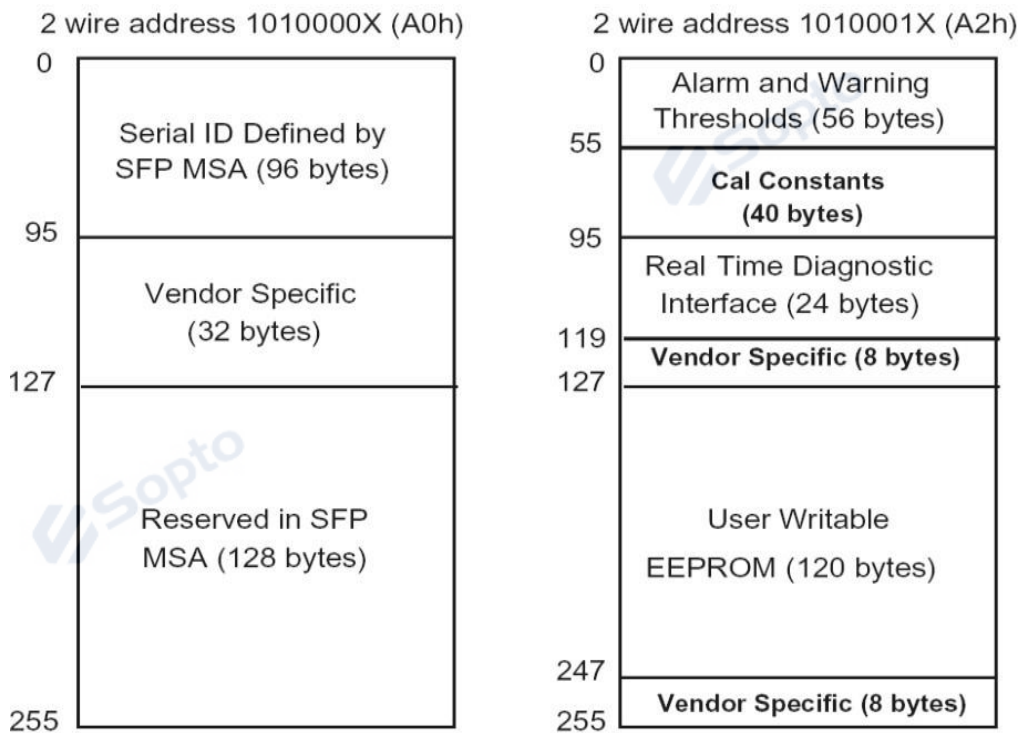

Pin Definitions

Pin Diagram

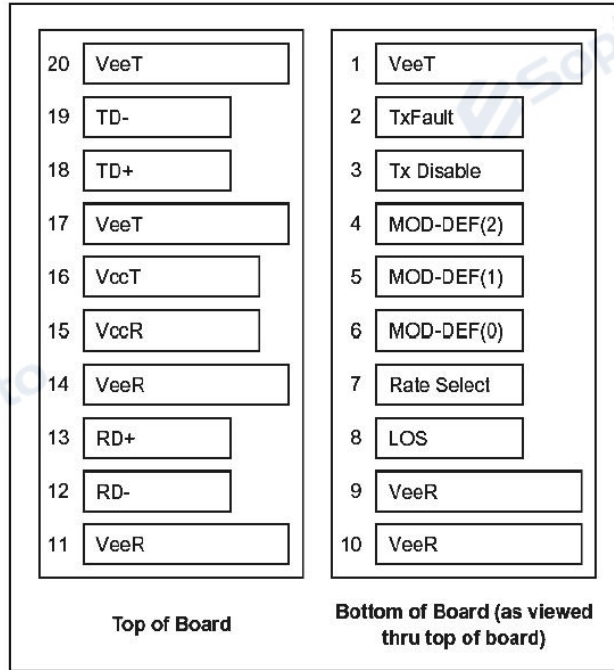

Pin Descriptions

Pin	Signal Name	Description	Plug Seq.	Notes
1	V _{EET}	Transmitter Ground	1	
2	TX FAULT	Transmitter Fault Indication	3	Note 1
3	TX DISABLE	Transmitter Disable	3	Note 2
4	MOD_DEF(2)	SDA Serial Data Signal	3	Note 3
5	MOD_DEF(1)	SCL Serial Clock Signal	3	Note 3
6	MOD_DEF(0)	TTL Low	3	Note 3
7	Rate Select	Not Connected	3	
8	LOS	Loss of Signal	3	Note 4
9	V _{EER}	Receiver ground	1	
10	V _{EER}	Receiver ground	1	
11	V _{EER}	Receiver ground	1	
12	RD-	Inv. Received Data Out	3	Note 5
13	RD+	Received Data Out	3	Note 5
14	V _{EER}	Receiver ground	1	
15	V _{CCR}	Receiver Power Supply	2	
16	V _{CCT}	Transmitter Power Supply	2	
17	V _{EET}	Transmitter Ground	1	
18	TD+	Transmit Data In	3	Note 6
19	TD-	Inv. Transmit Data In	3	Note 6

20	V _{EET}	Transmitter Ground	1
----	------------------	--------------------	---

Notes:

Plug Seq.: Pin engagement sequence during hot plugging.

- 1) TX Fault is an open collector output, which should be pulled up with a 4.7k~10kΩ resistor on the host board to a voltage between 2.0V and V_{cc}+0.3V. Logic 0 indicates normal operation; Logic 1 indicates a laser fault of some kind. In the low state, the output will be pulled to less than 0.8V.
- 2) TX Disable is an input that is used to shut down the transmitter optical output. It is pulled up within the module with a 4.7k~10kΩ resistor. Its states are:
 - Low (0 to 0.8V): Transmitter on
 - (>0.8V, < 2.0V): Undefined
 - High (2.0 to 3.465V): Transmitter Disabled
 - Open: Transmitter Disabled
- 3) Mod-Def. 0, 1, 2. These are the module definition pins. They should be pulled up with a 4.7k~10kΩ resistor on the host board.
 - The pull-up voltage shall be V_{cc}T or V_{cc}R.
 - Mod-Def. 0 is grounded by the module to indicate that the module is present
 - Mod-Def. 1 is the clock line of two wire serial interface for serial ID
 - Mod-Def. 2 is the data line of two wire serial interface for serial ID
- 4) LOS is an open collector output, which should be pulled up with a 4.7k~10kΩ resistor. Pull up voltage between 2.0V and V_{cc}+0.3V. Logic 1 indicates loss of signal; Logic 0 indicates normal operation. In the low state, the output will be pulled to less than 0.8V.
- 5) RD-/+ : These are the differential receiver outputs. They are internally AC-coupled 100 differential lines which should be terminated with 100Ω (differential) at the user SERDES.
- 6) TD-/+ : These are the differential transmitter inputs. They are internally AC-coupled, differential lines with 100Ω differential termination inside the module.

Recommended Interface Circuit

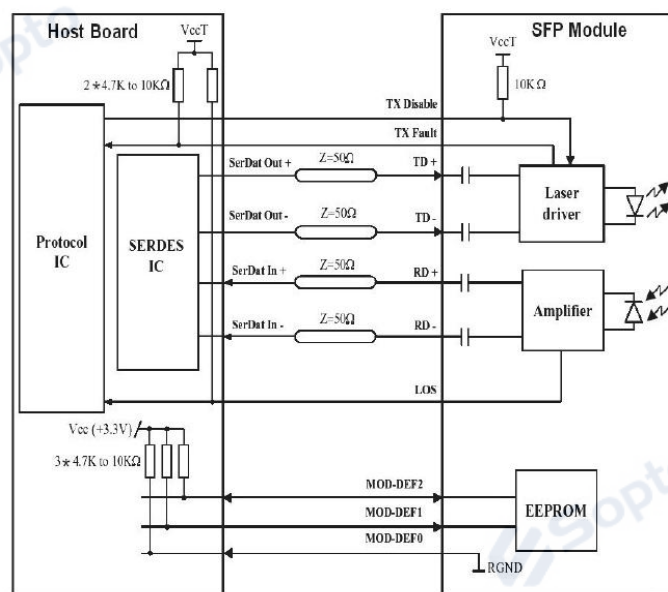

Mechanical Dimensions

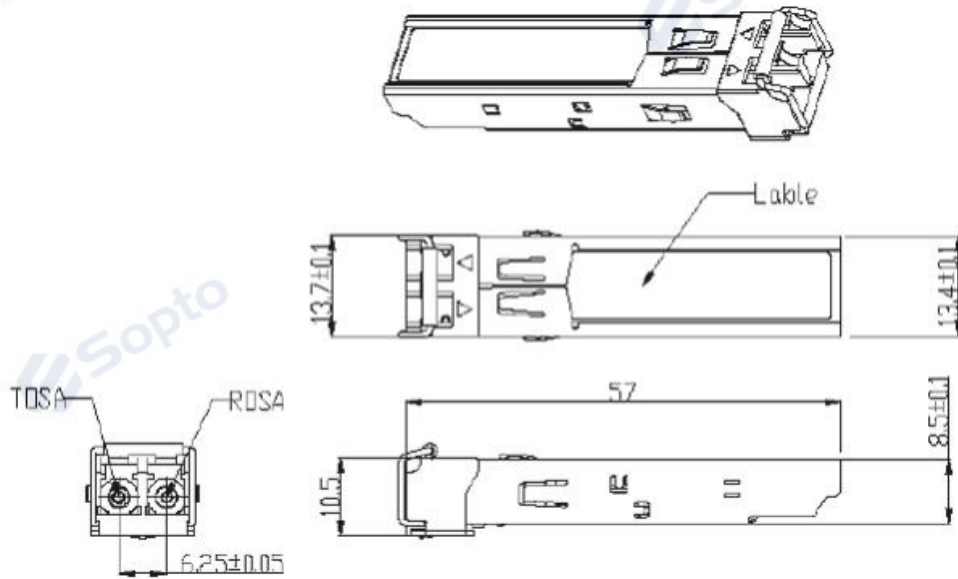

Unit:mm

Ordering information

Part Number	Product Description
SPT-P854G-S3D	850nm, 4.25Gbps,300m, 0°C~+70°C, DDM
SPT-P854G-S3TD	850nm,4.25Gbps,300m, -40°C~+85°C, DDM

E-mail: info@sopto.com.cn

Web : <http://www.sopto.com.cn>