

## SPPT-PBXX-X80D

### 2.5Gbps SFP Bi-Directional Transceiver, 80km Reach

1490nm Tx/ 1550nm Rx & 1550nm Tx/ 1490nm Rx

#### Features

- Dual data-rate of 2.488Gbps/2.125Gbps operation
- 1490nm or 1550nm DFB laser and PIN photo detector for 80km transmission
- Compliant with SFP MSA and SFF-8472 with simplex LC or SC receptacle
- Digital Diagnostic Monitoring: Internal Calibration or External Calibration
- Compatible with SONET OC-48 system
- Compatible with RoHS
- +3.3V single power supply
- Operating case temperature range of 0°C to +70°C (Commercial) or -40°C to +85°C (Industrial)

#### Applications

- SDH STM-16 and SONET OC-48 system
- Fiber Channel
- Switch to Switch interface
- Switched backplane applications
- Router/Server interface
- Other optical transmission systems

#### Description

The SFP-BIDI transceivers are high performance, cost effective modules supporting dual data-rate of 2.488Gbps/2.125Gbps and 80km transmission distance with SMF.

The transceiver consists of three sections: a DFB laser transmitter, a PIN photodiode integrated with a trans-impedance preamplifier (TIA) and MCU control unit. All modules satisfy class I laser safety requirements

The transceivers are compatible with SFP Multi-Source Agreement (MSA) and SFF-8472. For further information, please refer to SFP MSA.

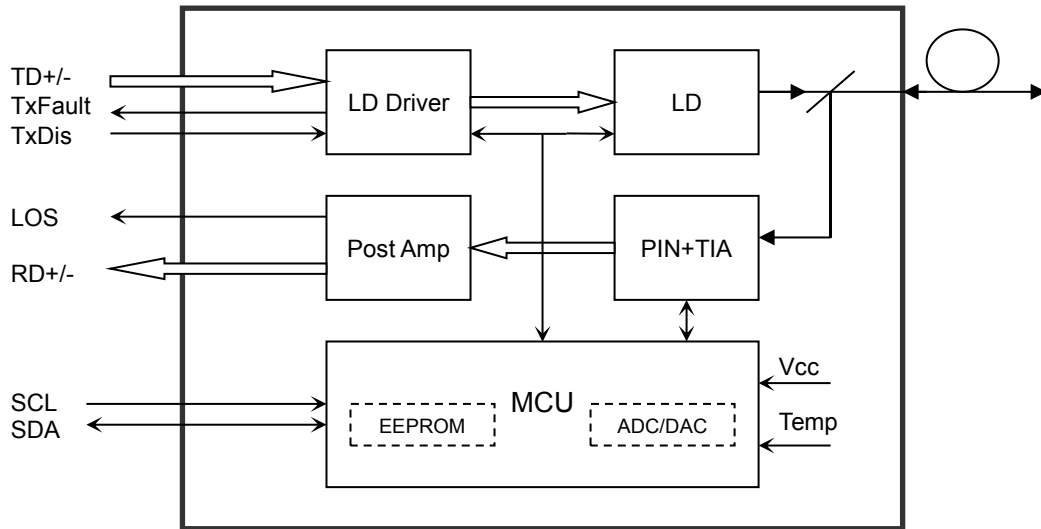

### Absolute Maximum Ratings

Parameter	Symbol	Min	Max	Unit
Supply Voltage	Vcc	-0.5	4	V
Storage Temperature	Ts	-40	+85	°C
Operating Humidity	-	5	85	%

### Recommended Operating Conditions

Parameter	Symbol	Min	Typical	Max	Unit
Operating Case Temperature	Standard	Tc	0	+70	°C
	Industrial		-40	85	°C
Power Supply Voltage	Vcc	3.13	3.3	3.47	V
Power Supply Current	Icc			170	mA
Data Rate	Gigabit Ethernet		2.488		Gbps
	Fiber Channel		1.063		

### Optical and Electrical Characteristics

Parameter	Symbol	Min	Typical	Max	Unit	Notes
<b>Transmitter</b>						
Centre Wavelength	$\lambda_c$	1470	1490	1510	nm	1490nm TX
		1500	1550	1580	nm	1550nm TX
Spectral Width (RMS)	$\Delta\lambda$			1	nm	
Side Mode Suppression Ratio	SMSR	30			dB	



Average Output Power	P <sub>out</sub>	-3		0	dBm	
Extinction Ratio	ER	9			dB	
Optical Rise/Fall Time (20%~80%)	t <sub>r</sub> /t <sub>f</sub>			0.16	ns	
Data Input Swing Differential	V <sub>IN</sub>	400		1800	mV	2
Input Differential Impedance	Z <sub>IN</sub>	90	100	110	Ω	
TxDisable	Disable		2.0		V <sub>cc</sub>	V
	Enable		0		0.8	V
TxFault	Fault		2.0		V <sub>cc</sub>	V
	Normal		0		0.8	V
<b>Receiver</b>						
Receiver Sensitivity				-28	dBm	3
Receiver Overload		-1			dBm	3
LOS De-Assert	LOS <sub>D</sub>			-29	dBm	
LOS Assert	LOS <sub>A</sub>	-40			dBm	
LOS Hysteresis		0.5	3	5	dB	
Data Output Swing Differential	V <sub>out</sub>	400		1800	mV	4
LOS	High	2.0			V <sub>cc</sub>	V
	Low			0.8	V	

Notes:

1. The optical power is launched into SMF.
2. PECL input, internally AC-coupled and terminated.
3. Measured with a PRBS 2<sup>7</sup>-1 test pattern @1250Mbps, BER ≤1×10<sup>-12</sup>.
4. Internally AC-coupled.

## Timing and Electrical

Parameter	Symbol	Min	Typical	Max	Unit
TxDisable Negate Time	t <sub>on</sub>			1	ms
TxDisable Assert Time	t <sub>off</sub>			10	μs
Time To Initialize, including Reset of TxFault	t <sub>init</sub>			300	ms
TxFault Assert Time	t <sub>fault</sub>			100	μs
TxDisable To Reset	t <sub>reset</sub>	10			μs
LOS Assert Time	t <sub>loss_on</sub>			100	μs
LOS De-assert Time	t <sub>loss_off</sub>			100	μs
Serial ID Clock Rate	f <sub>serial_clock</sub>			400	KHz

MOD_DEF (0:2)-High	VH	2		Vcc	V
MOD_DEF (0:2)-Low	VL			0.8	V

## Diagnostics

Parameter	Range	Unit	Accuracy	Calibration
Temperature	0 to +70	°C	±3°C	Internal / External
Voltage	3.0 to 3.6	V	±3%	Internal / External
Bias Current	0 to 100	mA	±10%	Internal / External
TxPower	-3 to 0	dBm	±3dB	Internal / External
Rx Power	-28 to -1	dBm	±3dB	Internal / External

## Digital Diagnostic Memory Map

The transceivers provide serial ID memory contents and diagnostic information about the present operating conditions by the 2-wire serial interface (SCL, SDA). The diagnostic information with internal calibration or external calibration all are implemented, including received power monitoring, transmitted power monitoring, bias current monitoring, supply voltage monitoring and temperature monitoring. The digital diagnostic memory map specific data field defines as following.

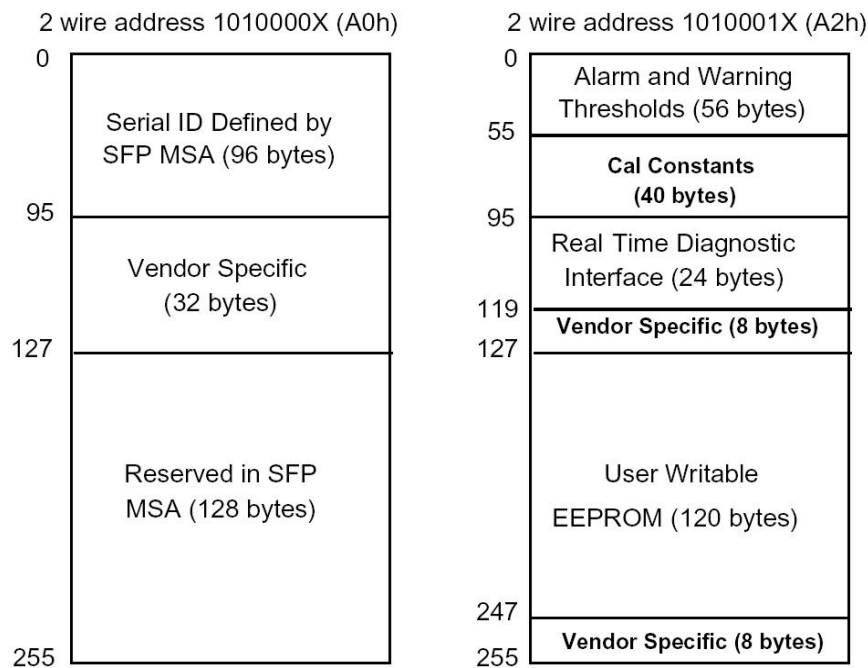

## Pin Definitions

### Pin Diagram

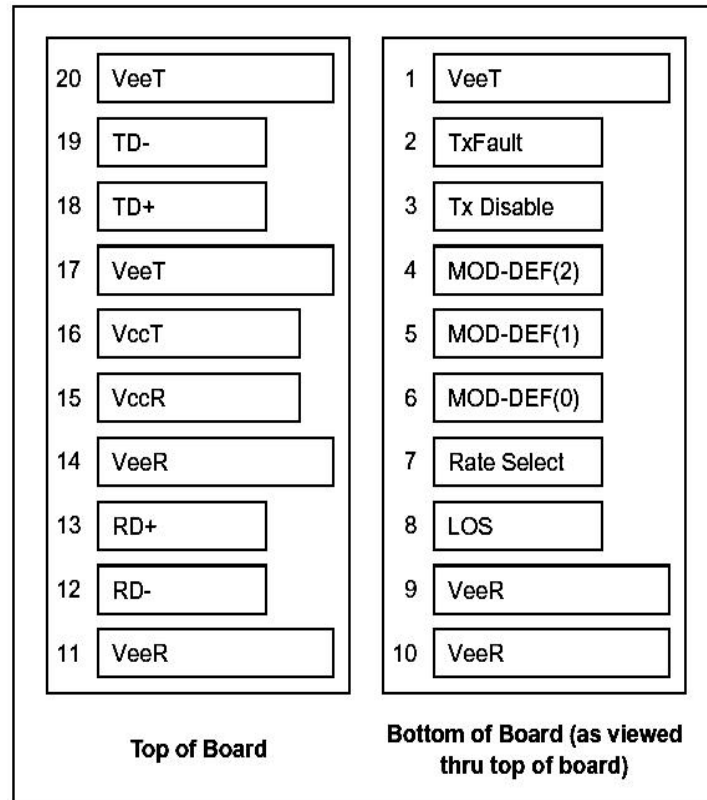

## Pin Descriptions

Pin	Signal Name	Description	Plug Seq.	Notes
1	V <sub>EET</sub>	Transmitter Ground	1	
2	TxF <sub>FAULT</sub>	Transmitter Fault Indication	3	Note 1
3	TxD <sub>DISABLE</sub>	Transmitter Disable	3	Note 2
4	MOD_DEF(2)	SDA Serial Data Signal	3	Note 3
5	MOD_DEF(1)	SCL Serial Clock Signal	3	Note 3
6	MOD_DEF(0)	TTL Low	3	Note 3
7	Rate Select	Not Connected	3	
8	LOS	Loss of Signal	3	Note 4
9	V <sub>EER</sub>	Receiver ground	1	
10	V <sub>EER</sub>	Receiver ground	1	
11	V <sub>EER</sub>	Receiver ground	1	
12	RD-	Inv. Received Data Out	3	Note 5
13	RD+	Received Data Out	3	Note 5
14	V <sub>EER</sub>	Receiver ground	1	
15	V <sub>CCR</sub>	Receiver Power Supply	2	
16	V <sub>CCT</sub>	Transmitter Power Supply	2	
17	V <sub>EET</sub>	Transmitter Ground	1	
18	TD+	Transmit Data In	3	Note 6
19	TD-	Inv. Transmit Data In	3	Note 6
20	V <sub>EET</sub>	Transmitter Ground	1	

### Notes:

Plug Seq.: Pin engagement sequence during hot plugging.

1) TxFault is an open collector output, which should be pulled up with a 4.7k~10kΩ resistor on the host board to a voltage between 2.0V and Vcc+0.3V. Logic 0 indicates normal operation; Logic 1 indicates a laser fault of some kind. In the low state, the output will be pulled to less than 0.8V.

2) TxDisable is an input that is used to shut down the transmitter optical output. It is pulled up within the module with a 4.7k~10kΩ resistor. Its states are:

- Low (0 to 0.8V): Transmitter on
- (>0.8V, < 2.0V): Undefined
- High (2.0 to 3.465V): Transmitter Disabled
- Open: Transmitter Disabled

3) Mod-Def 0,1,2. These are the module definition pins. They should be pulled up with a 4.7k~10kΩ resistor on the host board. The pull-up voltage shall be VccT or VccR.

Mod-Def 0 is grounded by the module to indicate that the module is present

Mod-Def 1 is the clock line of two wire serial interface for serial ID

Mod-Def 2 is the data line of two wire serial interface for serial ID

4) LOS is an open collector output, which should be pulled up with a 4.7k~10kΩ resistor. Pull up voltage between 2.0V and Vcc+0.3V. Logic 1 indicates loss of signal; Logic 0 indicates normal operation. In the low state, the output will be pulled to less than 0.8V.

5) RD-/+ : These are the differential receiver outputs. They are internally AC-coupled 100 differential lines which should be terminated with 100Ω (differential) at the user SERDES.

6) TD-/+ : These are the differential transmitter inputs. They are internally AC-coupled, differential lines with 100Ω differential termination inside the module.

### Recommended Interface Circuit

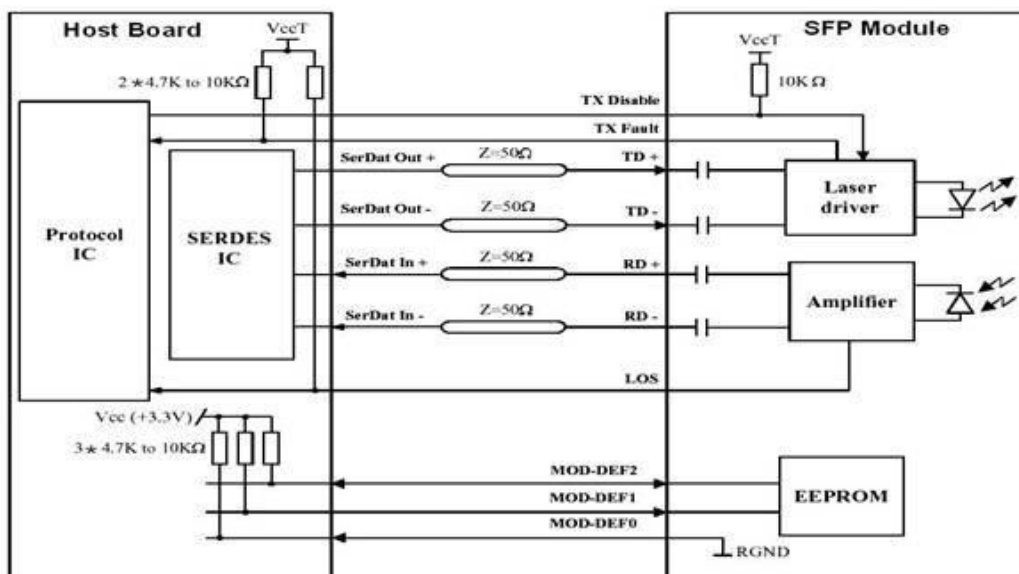

### Mechanical Dimensions

### A. LC Receptacle

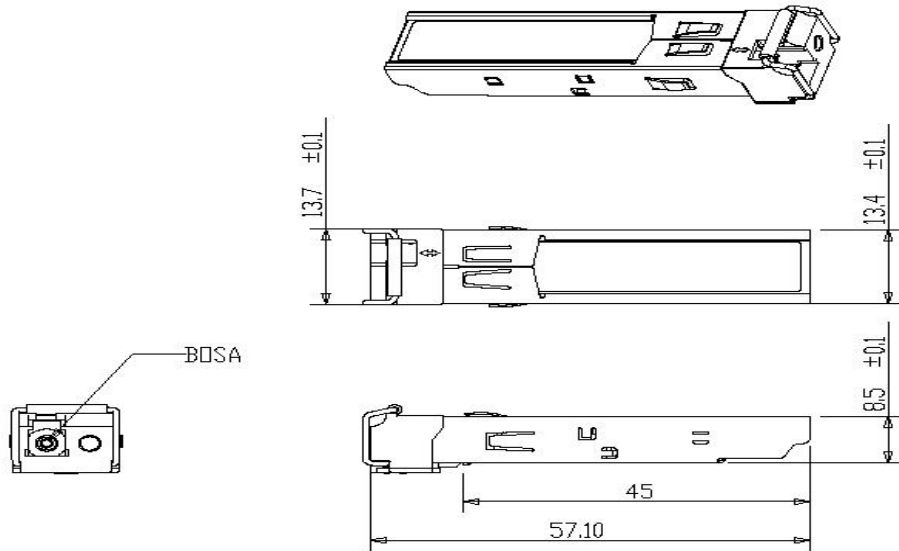

### B. SC Receptacle

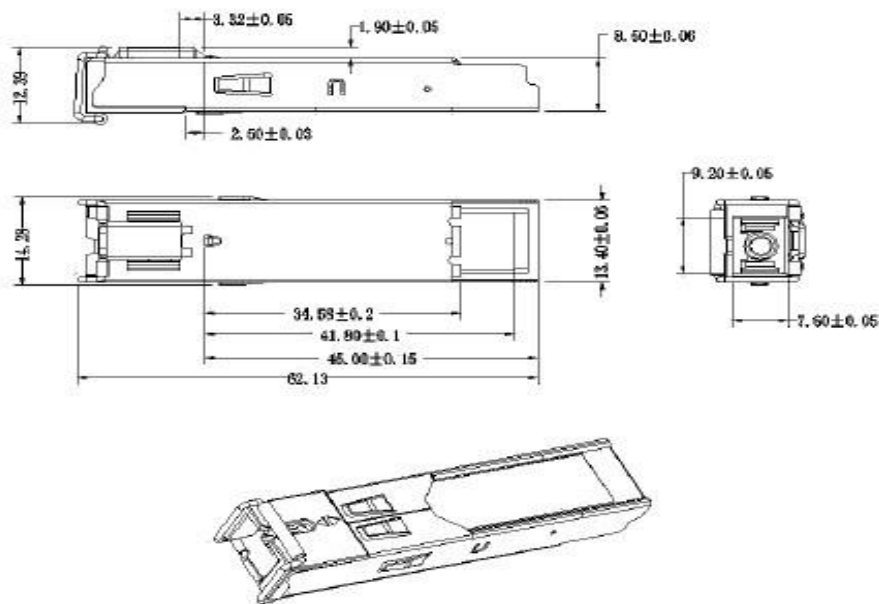

### Ordering information

Part Number	Product Description
	1490nm Tx/ 1550 nm Rx
SPT-PB4548-L80D	1490nm TX, 2.488Gbps, LC, 80km, 0°C~+70°C, With DDM
SPT-PB4548-S80D	1490nm TX, 2.488Gbps, SC, 80km, 0°C~+70°C, With DDM
	1550nm Tx/ 1490 nm Rx
SPT-PB5448-L80D	1550nm TX, 2.488Gbps, LC, 80km, 0°C ~ +70°C, With DDM

SPT-PB5448-S80D

1550nm TX, 2.488Gbps, SC, 80km, 0°C ~ +70°C, With DDM

Note:

- 1、 Default operating case temperature is 0 ~ 70°C. If you need -40 ~85°C products, please contact us.
- 2、 If you need more customized services, please contact us.

E-mail: [info@sopto.com.cn](mailto:info@sopto.com.cn)Web : <http://www.sopto.com.cn>