



# SPT-P3103-02(D)

SFP 155Mb/s Transceiver 2Km Hot Pluggable, Duplex LC, +3.3V 1310nm FP-LD MM, DDMI

## Features

- Up to 155M b/s Data Links
- Hot-Pluggable
- 1310nm FP laser transmitter
- Duplex LC connector
- RoHS compliant and Lead Free
- Up to 2 km on 50/125µm MMF
- Single +3.3V Power Supply
- Monitoring Interface Compliant with SFF-8472
- Operating case temperature:  
Standard: 0 to +70°C  
Industrial: -40 to +85°C

## Applications

- SONET OC-3 MM
- SDH STM-1 Ie-1
- Fast Ethernet
- Other Optical Links

## Description

SPT-P3103-02(D) Transceiver is a high performance, cost effective module which have a Duplex LC optics interface. Standard AC coupled CML for high speed signal and LVTTTL control and monitor signals.

The receiver section uses a PIN receiver and the transmitter uses 1310 nm FP laser, up to 17dB link budge ensure this module SONET OC-3/SDH STM-1 2Km application.

## Absolute Maximum Ratings

Parameter	Symbol	Min.	Typical	Max.	Unit
Storage Temperature	T <sub>s</sub>	-40		+85	°C
Supply Voltage	V <sub>CC</sub> T, R	-0.5		4	V
Relative Humidity	RH	0		85	%
Case Operating Temperature	Industrial	-40		85	°C
	Commercial	0		70	



### Recommended Operating Conditions

Parameter	Symbol	Min.	Typical	Max.	Unit
Case operating Temperature	Industrial	-40		85	°C
	Commercial	0		70	°C
Supply Voltage	$V_{CCT,R}$	3.0		3.6	V

### Electrical Characteristics (TOP = 0 to 70 °C, VCC = 3.0 to 3.60 Volts)

Parameter	Symbol	Min.	Typical	Max.	Unit	Note
Supply Voltage	$V_{CC}$	3.0	3.30	3.60	V	
Supply Current	$I_{CC}$			160	mA	
Inrush Current	$I_{surge}$			$I_{CC}+30$	mA	
Maximum Power	$P_{max}$			1.0	W	
<b>Transmitter Section:</b>						
Input differential impedance	$R_{in}$	90	100	110	$\Omega$	
Single ended data input swing	$V_{in PP}$	200		1200	mVp-p	
Transmit Disable Voltage	$V_D$	$V_{CC} - 1.3$		$V_{CC}$	V	2
Transmit Enable Voltage	$V_{EN}$	$V_{EE}$		$V_{EE}+0.8$	V	
Transmit Disable Assert Time	$T_{dessert}$			10	us	
<b>Receiver Section:</b>						
Single ended data output swing	$V_{out,pp}$	300		1000	mv	3
Data output rise time	$t_r$			1300	ps	4
Data output fall time	$t_f$			1300	ps	4
LOS Fault	$V_{losfault}$	$V_{CC} - 0.5$		$V_{CC\_host}$	V	5
LOS Normal	$V_{los norm}$	$V_{EE}$		$V_{EE}+0.5$	V	5
Power Supply Rejection	PSR	100			mVpp	6

Note:

1. AC coupled.
2. Or open circuit.
3. Into 100 ohm differential termination.
4. 20 – 80 %
5. LOS is LVTTTL. Logic 0 indicates normal operation; logic 1 indicates no signal detected.
6. All transceiver specifications are compliant with a power supply sinusoidal modulation of 20 Hz to 1.5MHz up to specified value applied through the power supply filtering network shown on page 23 of the Small Form-factor Pluggable (SFP) Transceiver Multi-Source Agreement (MSA), September 14, 2000.

### Optical Parameters(TOP = 0 to 70 °C, VCC = 3.00 to 3.60 Volts)

Parameter	Symbol	Min.	Typical	Max.	Unit	Note
<b>Transmitter Section</b>						
Center Wavelength	$\lambda_c$	1270	1310	1360	nm	1
Spectral Width	$\sigma$			3	nm	
Optical Output Power	$P_{out}$	-15		-7	dBm	2



Optical Rise/Fall Time	$t_r / t_f$			1300	ps	3
Extinction Ratio	ER	8			dB	
Eye Mask for Optical Output	Compliant with Eye Mask Defined in IEEE 802.3 standard					
<b>Receiver Section</b>						
Optical Input Wavelength	$\lambda_c$	1100		1670	nm	
Receiver Overload	$P_{ol}$			-3	dBm	4.5
RX Sensitivity	Sen			-32	dBm	4.5
RX_LOS Assert	LOS <sub>A</sub>	-44			dBm	
RX_LOS Deassert	LOS <sub>D</sub>			-34	dBm	
RX_LOS Hysteresis	LOS <sub>H</sub>		2	2.5	dB	
<b>General Specifications:</b>						
Data Rate	BR		155		Mb/s	

### Digital Diagnostic Monitor Characteristics

The following digital diagnostic characteristics are defined over the Recommended Operating Environment unless otherwise specified. It is compliant to SFF8472 Rev10.2 with internal calibration mode. For external calibration mode please contact our sales staff.

Parameter	Symbol	Min.	Max.	Unit
Temperature monitor absolute error	DMI_Temp	-3	3	degC
Laser power monitor absolute error	DMI_TX	-3	3	dB
RX power monitor absolute error	DMI_RX	-3	3	dB
Supply voltage monitor absolute error	DMI_VCC	-0.1	0.1	V
Bias current monitor absolute error	DMI_Ibias	-10%	10%	mA

### Block Diagram of Transceiver

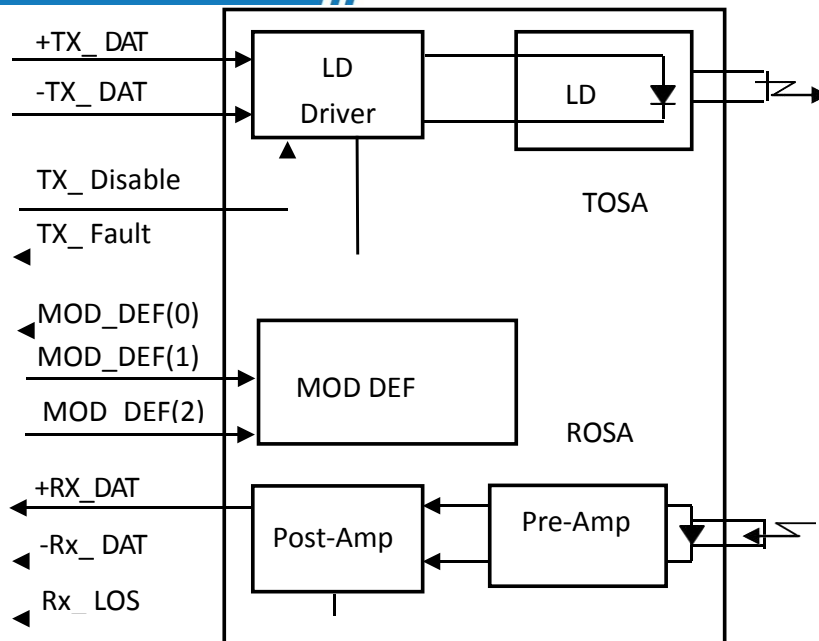

### Pin Definitions

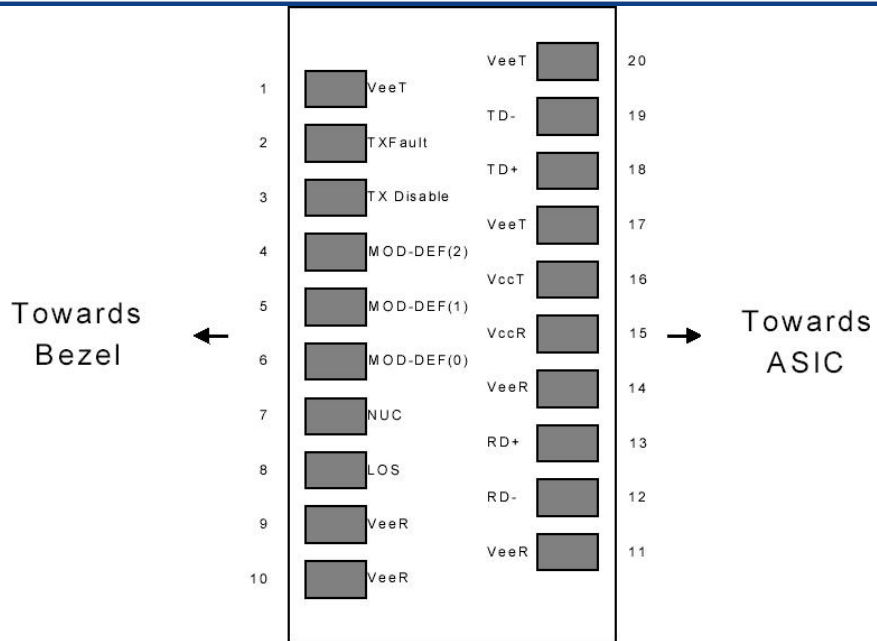

**Figure2:Diagram of Host Board Connector Block Pin Numbers and Names**

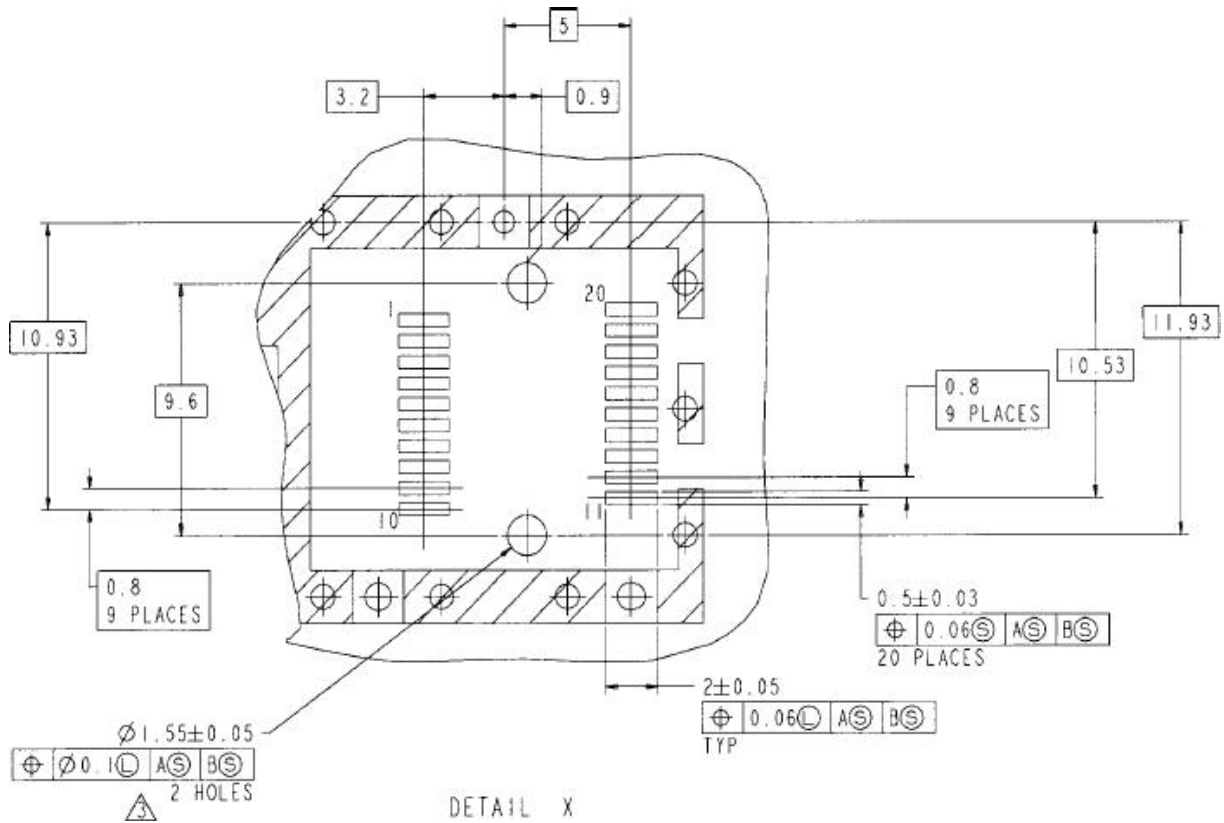

**Figure 3. SFP Host Board Mechanical Layout**

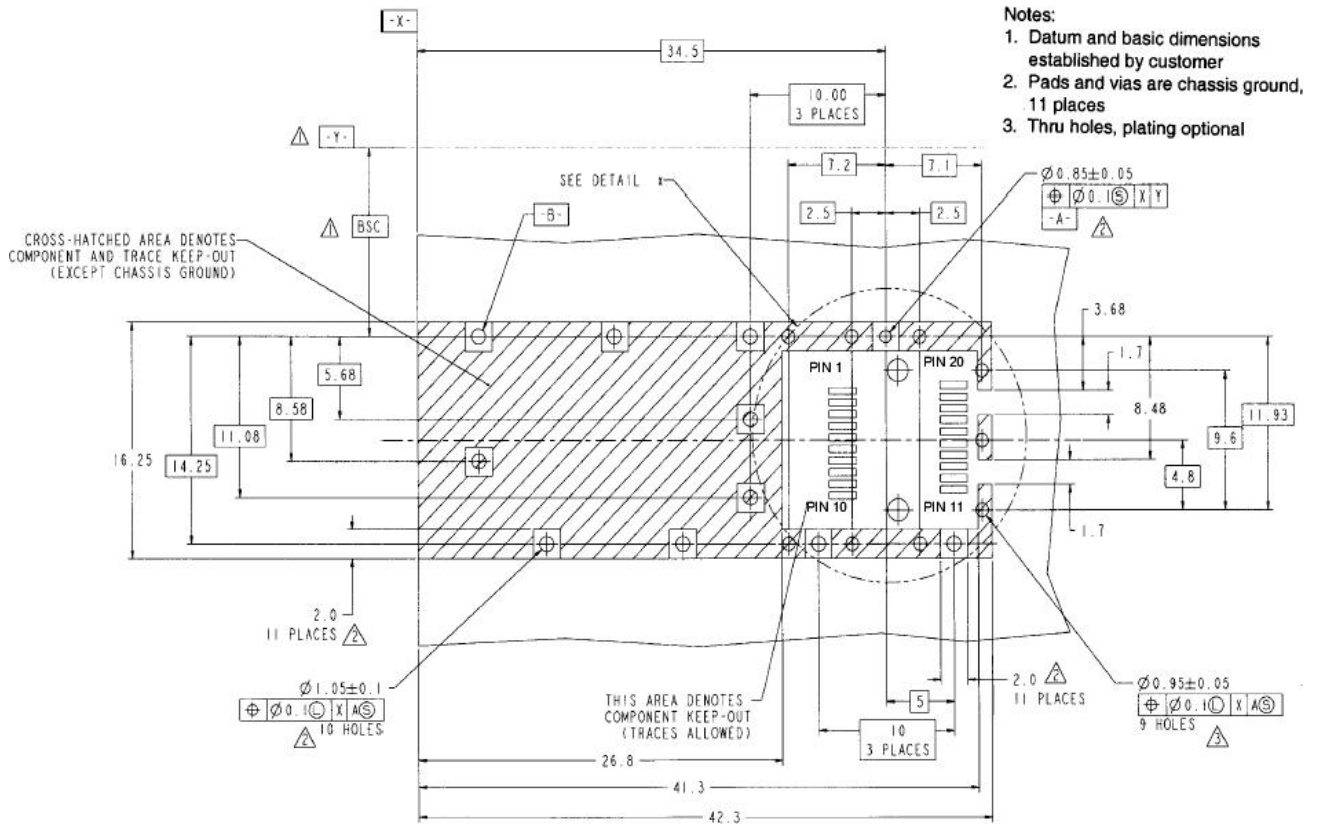

**Figure 4. SFP Host Board Mechanical Layout(Cont)**

**Pin Description:**

Pin No	Name	Function	Plug Seq	Notes
1	VeeT	Transmitter Ground	1	1
2	TX Fault	Transmitter Fault Indication	3	
3	TX Disable	Transmitter Disable	3	2
4	MOD-DEF2	Module Definition	2	3
5	MOD-DEF1	Module Definition 1	3	3
6	MOD-DEF0	Module Definition 0	3	3
7	Rate Select	Not Connected	3	4
8	LOS	Loss of Signal	3	5
9	VeeR	Receiver Ground	1	1
10	VeeR	Receiver Ground	1	1
11	VeeR	Receiver Ground		1
12	RD-	Inv. Received Data Out	3	6
13	RD+	Received Data Out	3	6
14	VeeR	Receiver Ground	3	1
15	VccR	Receiver Power	2	1
16	VccT	Transmitter Power	2	
17	VeeT	Transmitter Ground	1	
18	TD+	Transmit Data In	3	6
19	TD-	Inv. Transmit In	3	6
20	VeeT	Transmitter Ground	1	



Notes:

1. Circuit ground is internally isolated from chassis ground
2. Laser output disabled on TDIS >2.0V or open, enabled on TDIS <0.8V.
3. Should be pulled up with 4.7k - 10 kohms on host board to a voltage between 2.0V and 3.6V.MOD\_DEF(0) pulls line low to indicate module is plugged in.
4. Rate select is not used
5. LOS is open collector output. Should be pulled up with 4.7k – 10 kohms on host board to a voltage between 2.0V and 3.6V. Logic 0 indicates normal operation; logic 1 indicates loss of signal.
6. AC Coupled

Recommended Interface Circuit

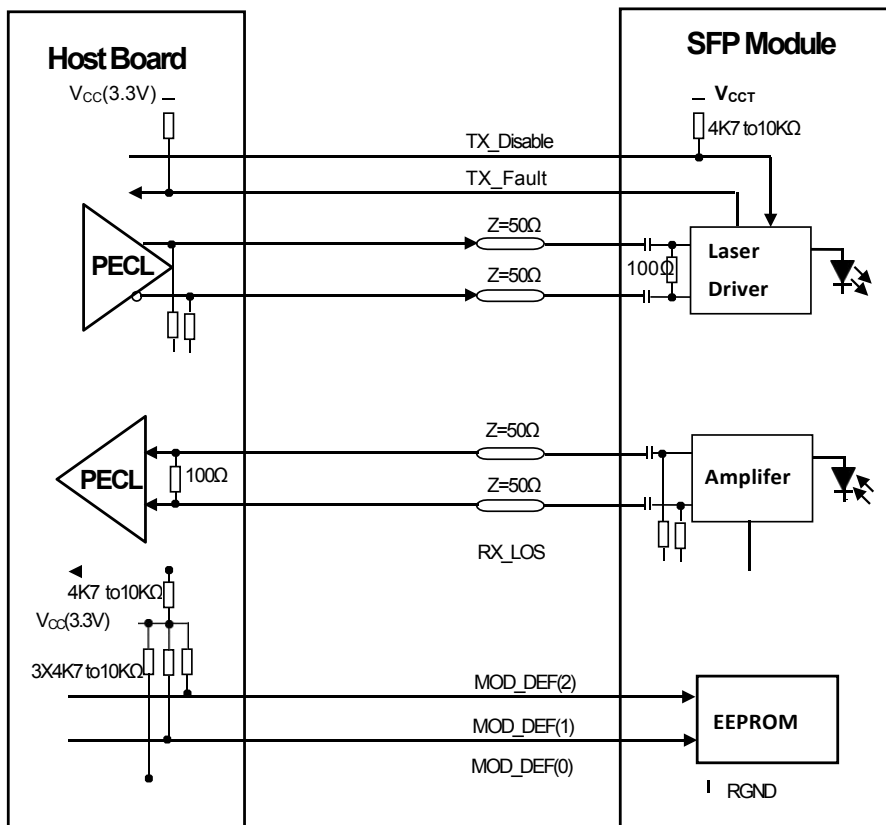

Figure 5. SFP Host Recommended Circuit

Serial ID Memory Contents

Data Address	Length (Byte)	Name of Length	Description and Contents
<b>Base ID Fields</b>			
0	1	Identifier	Type of Serial transceiver (03h=SFP)
1	1	Reserved	Extended identifier of type serial transceiver (04h)
2	1	Connector	Code of optical connector type (07=LC)
3-10	8	Transceiver	SONET
11	1	Encoding	SONET Scrambled
12	1	BR,Nominal	Nominal baud rate, unit of 100Mbps
13	1	Reserved	(0000h)
14	1	Length(9um,km)	Link length supported for 9/125um fiber, units of km



15	1	Length(9um)	Link length supported for 9/125um fiber, units of 100m
16	1	Length(50um)	Link length supported for 50/125um fiber, units of 10m
17	1	Length(62.5um)	Link length supported for 62.5/125um fiber, units of 10m
18	1	Length(Copper)	Link length supported for copper, units of meters
19	1	Reserved	
20-35	16	Vendor Name	SFP vendor name:
36	1	Reserved	
37-39	3	Vendor OUI	SFP transceiver vendor OUI ID
40-55	16	Vendor PN	Part Number: "xxxxx" (ASCII)
56-59	4	Vendor rev	Revision level for part number
60-61	2	Wavelength	Laser wavelength
62	1	Reserved	
63	1	CCID	Least significant byte of sum of data in address 0-62
<b>Extended ID Fields</b>			
64-65	2	Option	Indicates which optical SFP signals are implemented(001Ah = LOS, TX_FAULT, TX_DISABLE all supported)
66	1	BR, max	Upper bit rate margin, units of %
67	1	BR, min	Lower bit rate margin, units of %
68-83	16	Vendor SN	Serial number (ASCII)
84-91	8	Date code	Manufacturing date code
92	1	Diagnostic Type	Diagnostics
93	1	Enhanced Options	Diagnostics
94	1	SFF-8472	Diagnostics
95	1	CCEX	Check code for the extended ID Fields (addresses 64 to 94)
<b>Vendor Specific ID Fields</b>			
96-127	32	Readable	Vendor specific data, read only



## Diagnostics Memory

Data Address	Length (Byte)	Name of Length	Description and Contents
<b>Diagnostic and control/status fields</b>			
0-39	40	A/W Thresholds	Diagnostic Flag Alarm and Warning Thresholds
40-55	16	Unallocated	
56-91	16	Ext Cal Constants	Diagnostic calibration constants for optional External Calibration
92-94	3	Unallocated	
95	1	CC_DMI	Check code for Base Diagnostic Fields (addresses 0 to 94)
96-105	10	Diagnostics	Diagnostic Monitor Data (internally or externally calibrated)
106-109	4	Unallocated	
110	1	Status/Control	Optional Status and Control Bits
111	1	Reserved	Reserved for SFF-8079
112-113	2	Alarm Flags	Diagnostic Alarm Flag Status Bits
114-115	2	Unallocated	
116-117	2	Warning Flags	Diagnostic Warning Flag Status Bits
118-119	2	Ext Status/Control	Extended module control and status bytes
<b>General use fields</b>			
120-127	8	Vendor Specific	Vendor specific memory addresses
128-247	120	User EEPROM	User writable non-volatile memory
248-255	8	Vendor Control	Vendor specific control addresses

## References

1. Small Form-factor Pluggable (SFP) Transceiver Multi-source Agreement (MSA) September 14, 2000.
2. Bellcore GR-253 and ITU-T G.957 Specifications.

## Mechanical Dimensions



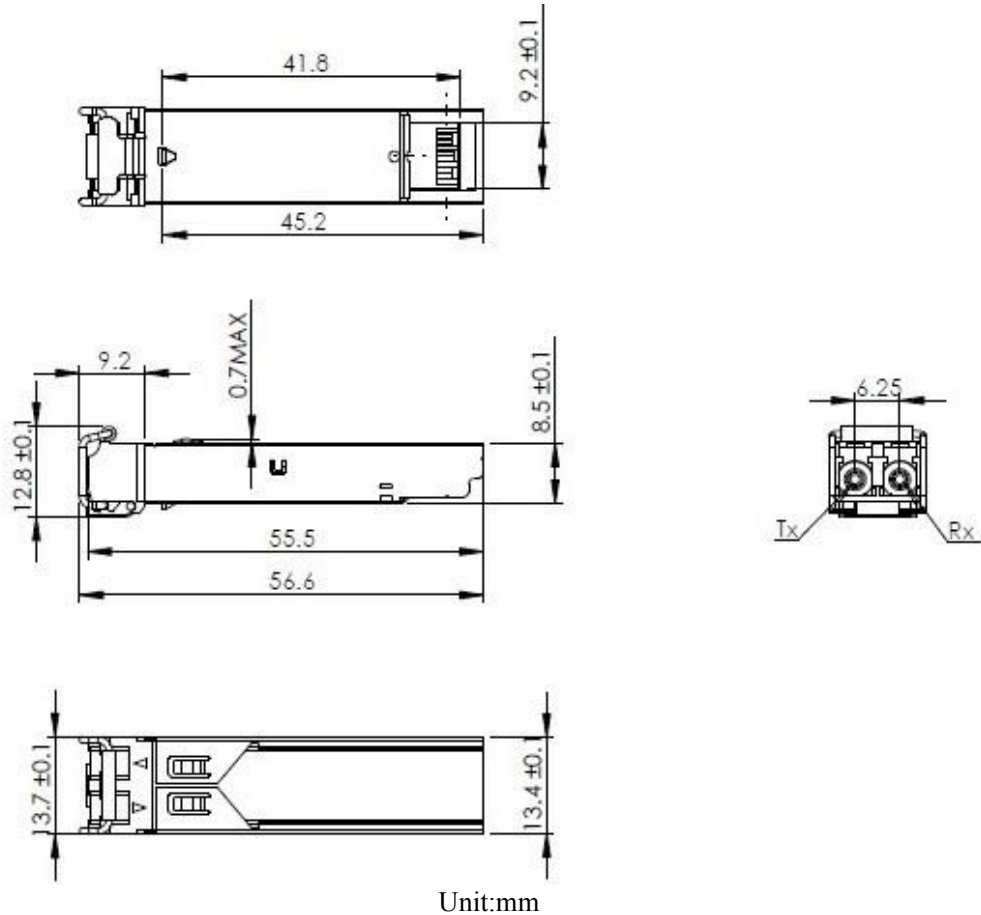

### Ordering information

Part Number	Product Description
SPT-P3103-02	1310nm MM, 155Mb/s, 2km/OM2, 0°C ~ +70°C
SPT-P3103-02D	1310nm MM, 155Mb/s, 2km/OM2, 0°C ~ +70°C, DDM
SPT-P3103-02TD	1310nm MM, 155Mb/s, 2km/OM2, -40°C ~ +85°C, DDM

Note: If you need more customized services, please contact us.

E-mail: [info@sopto.com.cn](mailto:info@sopto.com.cn)

Web : <http://www.sopto.com.cn>