

# SPT-EU3411-SE2AD

## EPON ONU SFP 1000BASE-PX20+ Transceiver

### Features

- BiDi SFP Single Mode Transceiver
- SC Receptacle is optional
- Compliant with SFF MSA-2000 And SFF-8472 V10.3
- Single +3.3 Power Supply
- LVPECL Differential Data Inputs And CML Data Outputs, LVTTTL Signal Detection Output
- Complies with Telcordia (Bellcore) GR-468-CORE
- 1310 nm Burst Mode Transmitter and 1490 nm Continuous Mode Receiver
- Typical data rate 1.25 Gbps
- Maximal reach 20km
- Comply with 1000Base-PX20+

### Applications

- GEPON ONU For P2MP Application

### General

The SOPTO SPT-EU3411-SE2AD transceiver with BiDi SFP package supports data rate of typical 1.25 Gbps for GEPON ONU application up to 20km transmission distance, it's designed meeting with 802.3ah and China Telecom 1000BASE-PX20+ specifications. SC Receptacle is for optical interface.

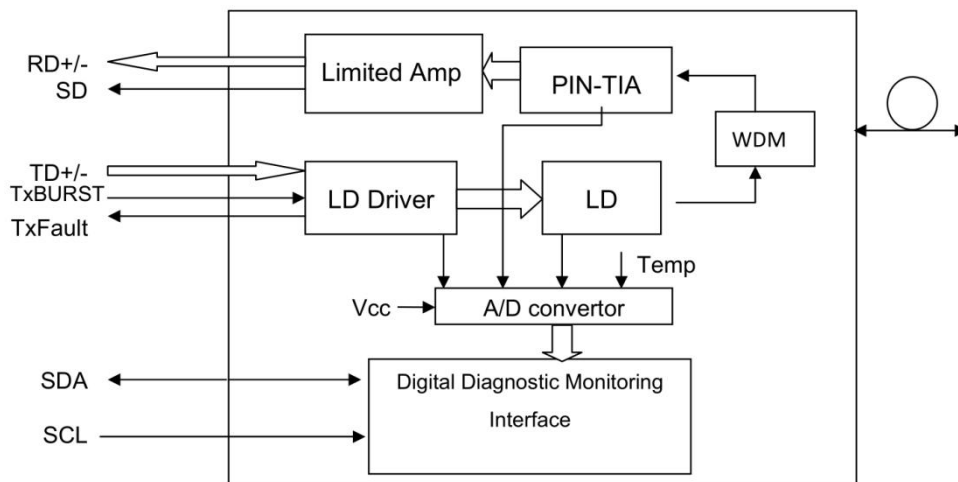

Fig 1 Transceiver Block Diagram

The module provides digital diagnostic information of its operating conditions and status, including transmitting power, laser bias, receiver input optical power, module temperature, and supply voltage. Calibration and alarm/warning threshold data are written and stored in internal memory (EEPROM). The memory map is compatible with SFF-8472, as shown in Fig. 2. The diagnostic data are raw A/D values and must be converted to real world units using calibration constants stored in EEPROM locations 56 – 95 in A2h.

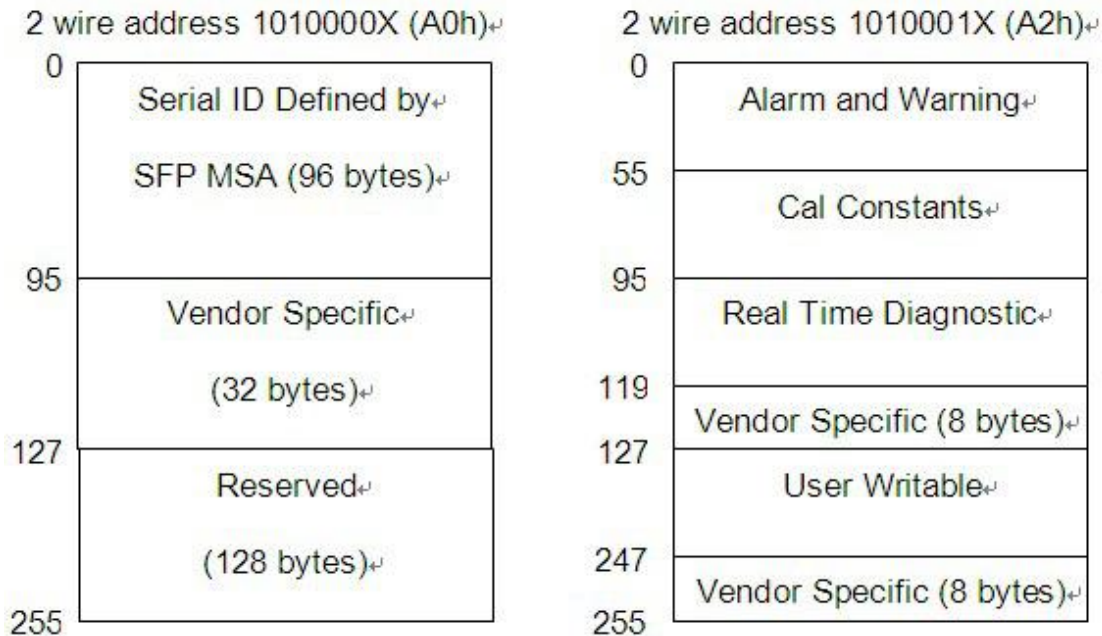

Fig 2 EEPROM Information

## Performance Specifications

### Absolute Maximum Ratings

Parameter	Symbol	Min.	Max.	Unit	Note
Storage Temperature	Tst	-40	+85	°C	
Operating Case Temperature	Tc	0	70	°C	Standard
		-40	+85		Industrial
Input Voltage	-	GND	Vcc	V	
Power Supply Voltage	Vcc-Vee	-0.5	+3.6	V	

### Recommended Operating Conditions

Parameter	Symbol	Min.	Typical	Max.	Unit	Note
Power Supply Voltage	Vcc	3.135	3.3	3.465	V	-
Operating Case Temperature	Tc	0	-	70	°C	Standard
		-40	-	85		Industrial
Data Rate	DR	-	1.25	-	Gbps	-
Total Supply Current	-	-	200	300	mA	-
Damage Threshold For Receiver	-	-	-	4	dBm	-

Optical Specification							
Transmitter							
Parameter		Symbol	Min.	Typ.	Max.	Unit	Note
Optical Central Wavelength		$\lambda$	1260	1310	1360	nm	
Spectral Width (RMS)	1260nm	$\Delta\lambda$	-	-	0.72	nm	
	1270nm		-	-	0.86		
	1280nm		-	-	1.07		
	1290nm		-	-	1.4		
	1300nm		-	-	2.0		
	1304nm		-	-	2.5		
	1305nm		-	-	2.55		
	1308nm 1317nm		-	-	3.0		
	1320nm		-	-	2.53		
	1321nm		-	-	2.41		
	1330nm		-	-	1.71		
	1340nm		-	-	1.29		
	1350nm		-	-	1.05		
	1360nm		-	-	0.88		
Average Optical Output Power		Po	0	-	4	dBm	
Extinction Ratio		Er	9	-	-	dB	-
Tx Burst ON Time		Ton	-	-	50	ns	-
Tx Burst OFF Time		Toff	-	-	50	ns	-
Rise/Fall Time		Tr/Tf	-	-	260	ps	-
Transmitter Total Jitter		Jp-p	-	-	280	ps	
Average Launched Power of Off Transmitter		Poff	-	-	-45	dBm	-
Output Eye	Compliant with IEEE 802.3ah-2004						
Receiver							
Parameter		Symbol	Min.	Typ.	Max.	Unit	Note
Operate Wavelength		-	1480	-	1500	nm	-
Sensitivity		Pr	-	-	-27	dBm	1
Saturation		Ps	-3	-	-	dBm	1
SD De-assert Level		-	-44	-	-	dBm	-
SD Assert Level		-	-	-	-27	dBm	-
SD Hysteresis		-	0.5	-	5	dB	-
Optical Reflectance		-	-	-	-12	dB	-
Optical Isolation from external source		ISO1	38	-	-	dB	$\lambda=1550\text{nm}$
		ISO2	35	-	-	dB	$\lambda=1650\text{nm}$

Note:

1. Minimum Sensitivity and saturation levels for a  $2^7-1$  NRZ PRBS.  $BER \leq 10^{-12}$ , 1.25Gpbs, ER=9dB

### Electrical Specification

Transmitter						
Parameter	Symbol	Min.	Typ.	Max.	Unit	Note
Differential Input Voltage	V <sub>IN-DIF</sub>	300	-	1600	mV	-
Tx Burst Input Voltage-Low	V <sub>IL</sub>	0	-	0.8	V	-
Tx Burst Input Voltage-High	V <sub>IH</sub>	2.0	-	V <sub>cc</sub>	V	-
Receiver						
Parameter	Symbol	Min.	Typ.	Max.	Unit	Note
Data Output Voltage Differential	V <sub>OUT-DIF</sub>	500	-	900	mV	-
Signal Detect Output Voltage-Low	V <sub>SD-L</sub>	0	-	0.8	V	-
Signal Detect Output Voltage-High	V <sub>SD-H</sub>	2.0	-	V <sub>cc</sub>	V	

### EEPROM Information

#### EEPROM Serial ID Memory Contents (A0h)

Addr. (decimal)	Field Size (Bytes)	Name of Field	Content (Hex)	Content (Decimal)	Description
0	1	Identifier	03	3	SFP
1	1	Ext. Identifier	04	4	MOD4
2	1	Connector	01	01	Receptacle
3-10	8	Transceiver	00 00 00 80 00 00 00 00	00 00 00 128 00 00 00 00	Transmitter Code
11	1	Encoding	01	1	8B10B
12	1	BR, nominal	0C	12	1.25Gbps
13	1	Reserved	00	0	-
14	1	Length (9um)-km	14	20	20km
15	1	Length (9um)	C8	200	20km
16	1	Length (50um)	00	0	-
17	1	Length (62.5um)	00	0	-
18	1	Length (copper)	00	0	-
19	1	Reserved	00	0	-
20-35	16	Vendor name	Omitted	Omitted	'SOPTO' (ASCII)
36	1	Reserved	00	0	-
37-39	3	Vendor OUI	00 00 00	0 0 0	-
40-55	16	Vendor PN	Omitted	Omitted	SPT-EU3411-SE2 AD (ASCII)
56-59	4	Vendor rev	30 30 30 20	48 48 48 32	“000” (ASCII)
60-61	2	Wavelength	05 1E	05 30	1310
62	1	Reserved	00	0	-
63	1	CC BASE	-	-	Check sum of bytes 0 - 62
64	1	Reserved	00	0	

65	1	Options	1C	28	
66	1	BR, max	00	0	-
67	1	BR, min	00	0	-
68-83	16	Vendor SN	-	-	ASCII
84-91	8	Vendor date	-	-	Year (2 bytes), Month (2 bytes), Day (2 bytes)
92	1	DDM Type	58/68	88/104	External/Internal Calibrated
93	1	Enhanced Option	B0	176	LOS, TX_FAULT and Alarm/warning flags implemented
94	1	SFF-8472 Compliance	03	3	SFF-8472 Rev 10.3
95	1	CC EXT	-	-	Check sum of bytes 64 - 94
96-255	160	Vendor spec			

#### Alarm and Warning Thresholds (Serial ID A2H)

Parameter(Unit)	C Temp (°C)	I Temp (°C)	Voltage (V)	Bias (mA)	TX Power (dBm)	RX Power (dBm)
High Alarm	100	100	3.6	90	4	-3
Low Alarm	-10	-40	3	0	0	-27
High Warning	95	95	3.5	70	3.5	-4
Low Warning	0	-30	3.1	0	0.5	-26

#### Digital Diagnostic Monitor Accuracy

Parameter	Unit	Accuracy	Range	Calibration
Tx Optical Power	dB	±3	Po: -Pomin~Pomax dBm, Recommended operation conditions	External/Int ernal
Rx Optical Power	dB	±3	Pi: Ps~Pr dBm, Recommended operation conditions	External/Int ernal
Bias Current	%	±10	Id: 1-100mA, Recommended operating conditions	External/Int ernal
Power Supply Voltage	%	±3	Recommended operating conditions	External/Int ernal
Internal Temperature	°C	±3	Recommended operating conditions	External/Int ernal



19	TD-	Inv.Transmitter Data In	3	Note 8
20	VeeT	Transmitter Ground	1	Note 5

**Notes:**

- TX Fault is an open collector/drain output, which should be pulled up with a 4.7K–10K $\Omega$  resistor on the host board. Pull up voltage between 2.0V and VccT, R+0.3V. When high, output indicates a laser fault of some kind. Low indicates normal operation. In the low state, the output will be pulled to < 0.8V.
- TX Burst is an input that is used to enable/disable the transmitter optical output. Burst Logic ‘1’ or Logic ‘0’ Tx on ,pleaser refer to order information
 

Logic ‘0’	Low	0 – 0.8V
>0.8, < 2.0V		Undefined
Logic ‘1’	High	2.0 – 3.465V
Open		Undefined
- Mod-Def 0,1,2. These are the module definition pins. They should be pulled up with a 4.7K – 10K $\Omega$  resistor on the host board. The pull-up voltage shall be VccT or VccR.  
 Mod-Def 0 is grounded by the module to indicate that the module is present  
 Mod-Def 1 is the clock line of two wire serial interface for serial ID  
 Mod-Def 2 is the data line of two wire serial interface for serial ID
- LOS (Loss of Signal) is an open collector/drain output, which should be pulled up with a 4.7K – 10K $\Omega$  resistor. Pull up voltage between 2.0V and VccT, R+0.3V. When high, this output indicates the received optical power is below the worst-case receiver sensitivity (as defined by the standard in use). Low indicates normal operation. In the low state, the output will be pulled to < 0.8V.
- VeeR and VeeT may be internally connected within the SFP module.
- RD-/+ : These are the differential receiver outputs. They are DC coupled 100 $\Omega$  differential lines which should be terminated with 100 $\Omega$  (differential) at the user SERDES.
- VccR and VccT are the receiver and transmitter power supplies. They are defined as 3.3V  $\pm$ 5% at the SFP connector pin. Maximum supply current is 450mA. Recommended host board power supply filtering is shown below. Inductors with DC resistance of less than 1 $\Omega$  should be used in order to maintain the required voltage at the SFP input pin with 3.3V supply voltage. When the recommended supply filtering network is used, hot plugging of the SFP transceiver module will result in an inrush current of no more than 30 mA greater than the steady state value. VccR and VccT may be internally connected within the SFP transceiver module.
- TD-/+ : These are the differential transmitter inputs. They are DC-coupled, differential lines with 100 $\Omega$  differential termination inside the module.

## Recommended Interface Circuit

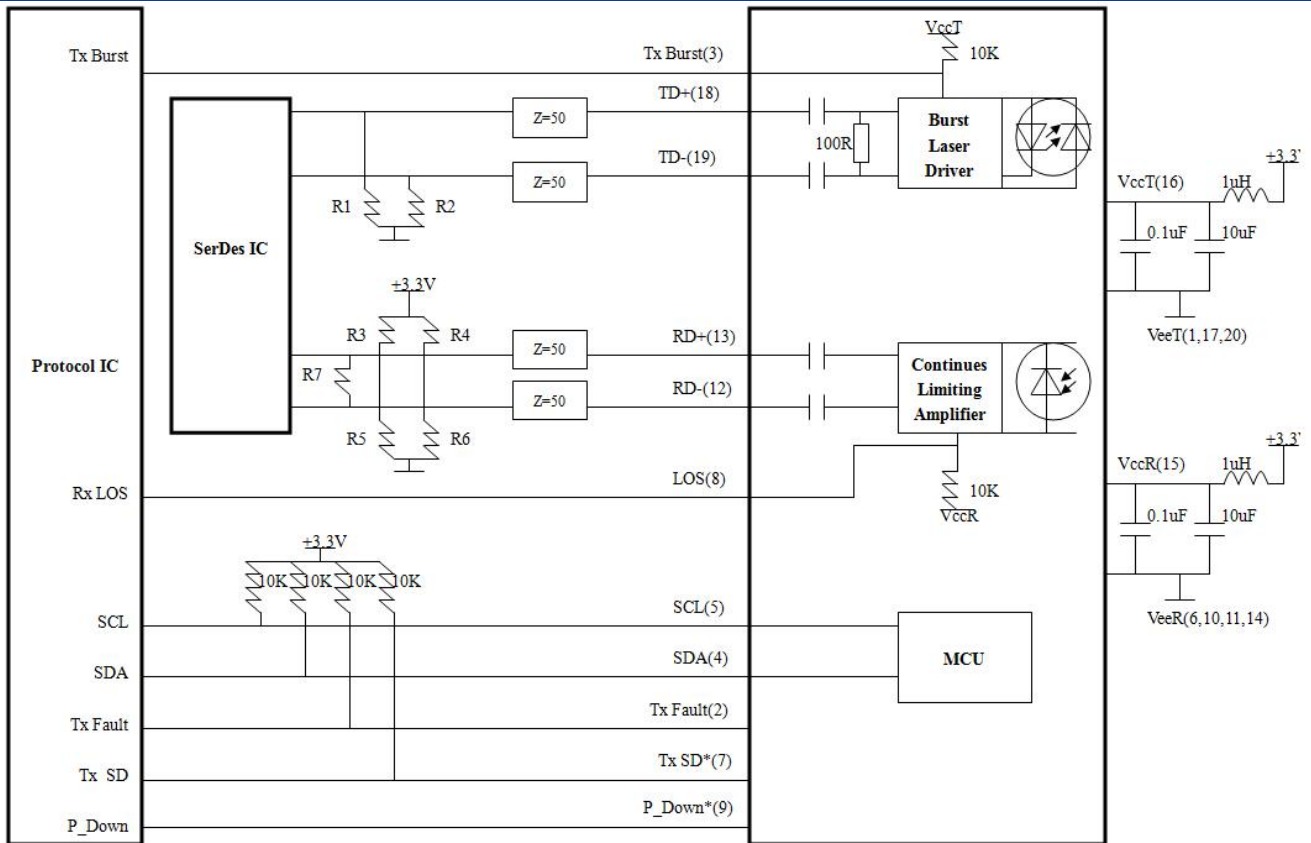

Note: (1) If use the No\_Tx\_SD Part No. , please let pin20 in ONU BOX N.C. .

(2) Tx: AC coupled internally.

R1=R2=150Ω.

Rx: AC coupled internally.

Input stage in SerDes IC with internal bias to Vcc-1.3V

R3=R4=R5=R6=N.C, R7=100Ω

Input stage in SerDes IC without internal bias to Vcc-1.3V

R3=R4=82Ω,R5=R6=130Ω,R7=N.C

## Burst Mode Sequence Definition

Tx Burst control: Logic '1' Tx ON

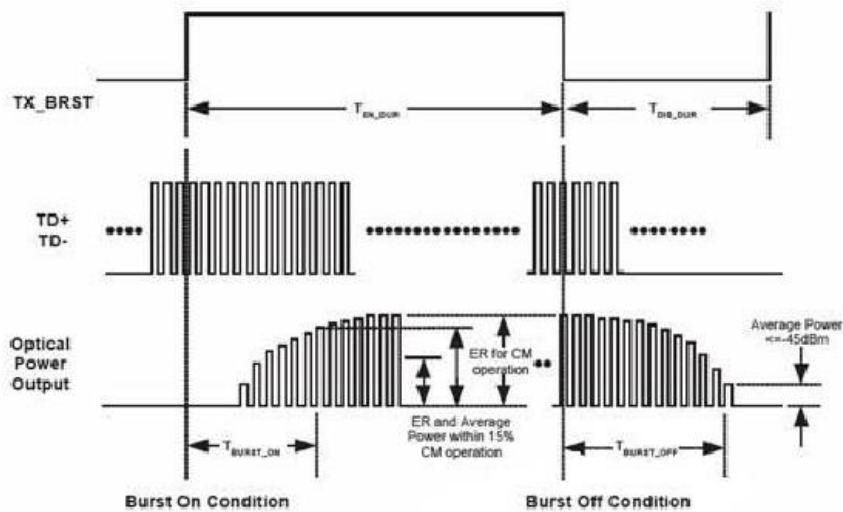



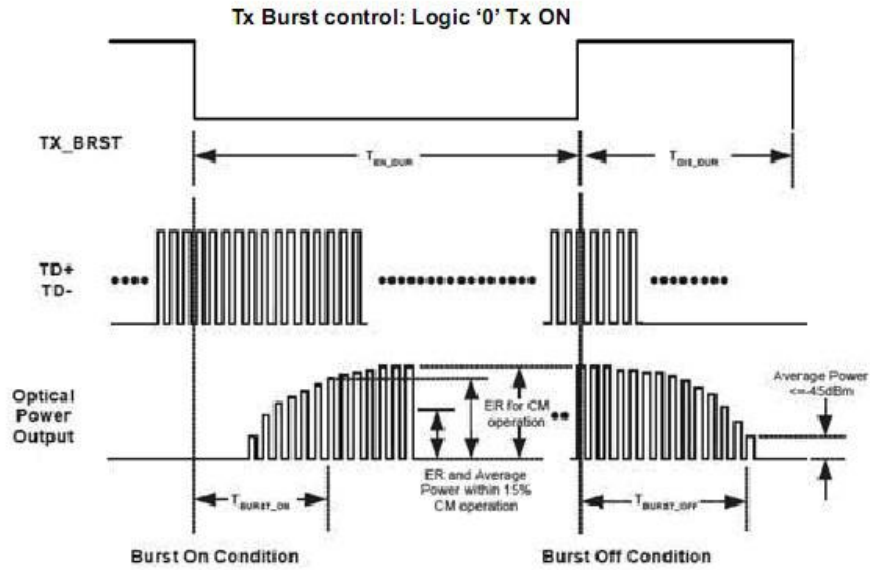

### Mechanical Dimensions

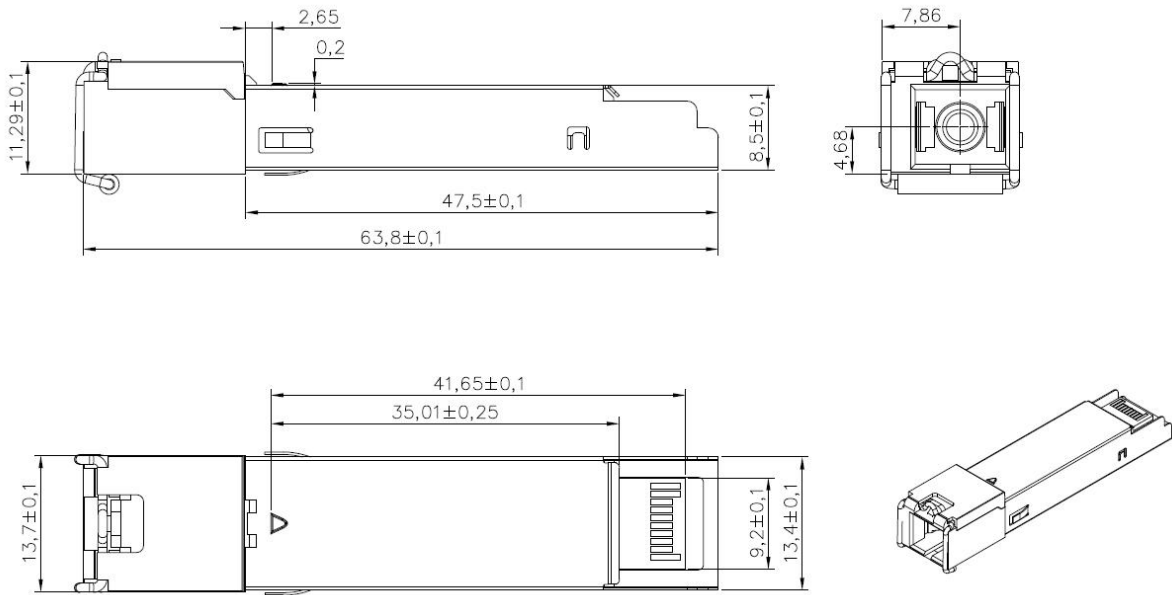

Unit: mm

### Ordering information

Ordering P/Ns	Description
SPT-EU3411-SE2AD-1	EPON ONU SFP Transceiver 1310nmTx/1490nmRx 1.25G/1.25G SC Interface 1000BASE-PX20+ with DDM Commercial Temperature Burst Logic 1 Tx On , with TxSD



SPT-EU3411-SE2AD-0

EPON ONU SFP Transceiver 1310nmTx/1490nmRx 1.25G/1.25G SC  
Interface 1000BASE-PX20+ with DDM Commercial Temperature  
Burst Logic 0 Tx On , with TxSD

E-mail: [info@sopto.com.cn](mailto:info@sopto.com.cn)

Web : <http://www.sopto.com.cn>