

EPON OLT SFP Transceiver

1000BASE-PX20/PX20+/PX20++

Product Features

- SC BIDI SFP Single Mode Transceiver
- Compliant with SFP MSA and SFF-8472
- Hot-pluggable
- Single +3.3 Power Supply
- Complies with Telcordia (Bellcore) GR-468-CORE
- 1490nm Continuous Mode Transmitter and 1310nm Burst Mode APD-TIA Receiver
- Typical data rate 1.25 Gbps, Maximal reach 20km
- Comply with China Telecom EPON equipment technical requirement V2.1 1000BASE-PX20+

Product Applications

- GEAPON OLT For P2MP Application

General

The EPON OLT SFP transceiver with supports data rate of typical 1.25 Gbps for GEAPON OLT application up to 20km transmission distance, it's designed meeting with China Telecom EPON equipment technical requirement V2.1 1000BASE-PX20+specifications. SC receptacle is for optical interface.

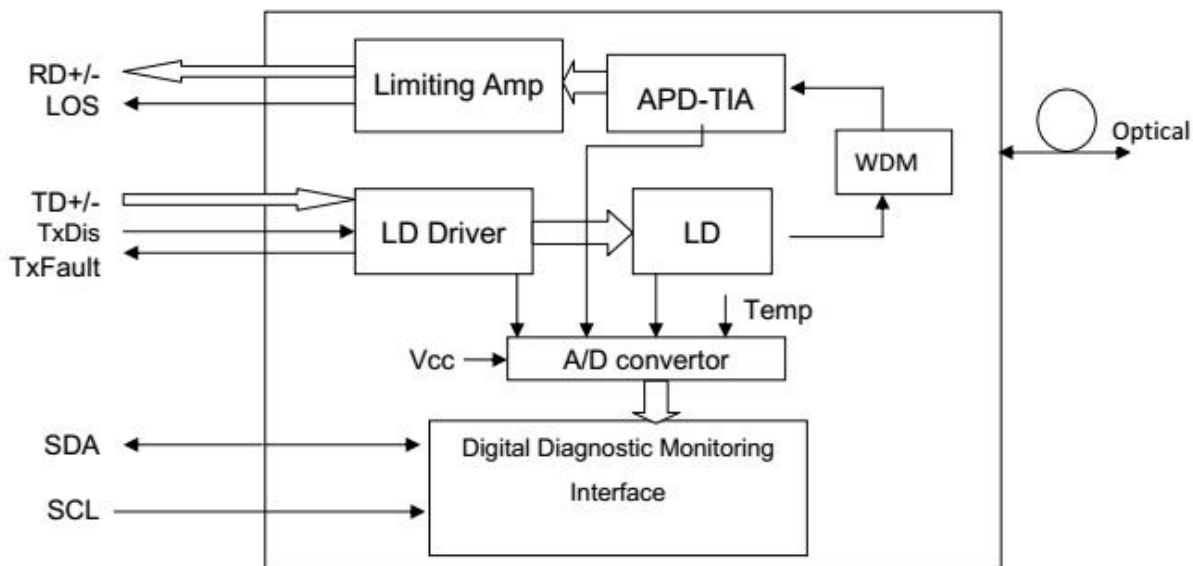

Fig 1 Transceiver Block Diagram

The module provides digital diagnostic information of its operating conditions and status, including transmitting power, laser bias, receiver input optical power, module temperature, and supply voltage. Calibration and alarm/warning threshold data are written and stored in internal memory (EEPROM). The memory map is compatible with SFF-8472, as shown in Fig.2. The diagnostic data are raw A/D values and must be converted to real world units using calibration constants stored in EEPROM locations 56–95 in A2h.

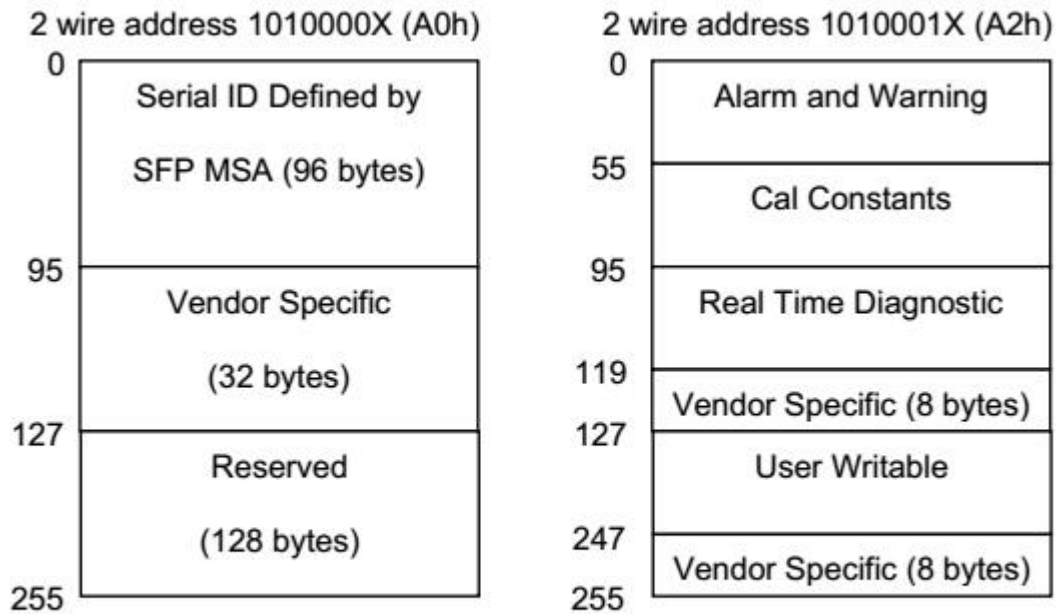

Fig 2 EEPROM Information

Performance Specifications

Absolute Maximum Ratings						
Parameter	Symbol	Min.	Max.	Unit	Note	
Storage Temperature	Tst	-40	+85	°C		
Operating Case Temperature	Tc	0	70	°C		
Input Voltage	-	GND	Vcc	V		
Power Supply Voltage	Vcc-Vee	-0.5	+3.6	V		
Recommended Operating Conditions						
Parameter	Symbol	Min.	Typical	Max.	Unit	Note
Power Supply Voltage	Vcc	3.135	3.3	3.465	V	
Operating Case	Tc	0	-	70	°C	

Temperature						
Data Rate	DR	-	1.25	-	Gbps	
Total Supply Current	-	-	-	400	mA	
Damage Threshold For Receiver	-	-	-	4	dBm	

Optical Specification

Transmitter

Parameter	Symbol	Min.	Typ.	Max.	Unit	Note
Optical Central Wavelength	λ	1480	1490	1500	nm	-
Spectral Width (-20dB)	$\Delta\lambda$	-	-	1	nm	-
Side Mode Suppression Ratio	SMSR	30	-	-	dB	-
Average Optical Output Power	Po	+2.5	+4	+7	dBm	PX20
		+3.5	+5	+7		PX20+
		+5	+7	+8		PX20++
Extinction Ratio	Er	9	-	-	dB	-
Rise/Fall Time	Tr/Tf	-	-	260	ps	-
Transmitter Total Jitter	Jp-p	-	-	344	ps	
Transmitter Reflectance	RFL	-	-	-12	dB	
Average Launched Power of Off Transmitter	Poff	-	-	-39	dBm	-
Differential Input Voltage	VIN-DIF	300	-	1600	mV	-
Tx Disable Input Voltage-Low	VIL	0	-	0.8	V	-
Tx Disable Input Voltage-High	VIH	2.0	-	Vcc	V	-
Output Eye	Compliant with IEEE 802.3ah-2004					

Receiver

Parameter	Symbol	Min.	Typ.	Max.	Unit	Note
Operate Wavelength	-	1280	1310	1340	nm	-
Sensitivity	Pr	-	-	-30	dBm	1
Saturation	Ps	-6	-	-	dBm	1
LOS assert Level	-	-45	-	-	dBm	-

LOS De-Assert Level	-	-	-	-30	dBm	-
LOS Hysteresis	-	0.5	-	5	dB	-
Receiver Optical Reflectance	-	-	-	-12	dB	-
Data Output Low	Vol	-2	-	-1.58	V	-
Data Output High	Voh	-1.1	-	-0.74	V	-
LOS Output Voltage-Low	VSD-L	0	-	0.8	V	-
LOS Output Voltage-High	VSD-H	2.0	-	Vcc	V	-

Note:

1. Minimum Sensitivity and saturation levels for an 8B10B 2⁷-1PRBS. BER ≤ 10⁻¹², 1.25Gpbs, ER=9dB

EEPROM Information

EEPROM Serial ID Memory Contents(A0h)

Addr.(decimal)	Field Size	Name of Field	Content(Hex)	Content(Decimal)	Description
0	1	Identifier	03	3	SFP
1	1	Ext. Identifier	04	4	MOD
2	1	Connector	01	1	SC
3-10	8	Transceiver	00 00 00 80 00 00 00 00	00 00 00 128 00 00 00 00	EPON
11	1	Encoding	01	1	8B10B
12	1	BR, nominal	0C	12	1.25Gbp
13	1	Reserved	00	0	-
14	1	Length(9um)-km	14	20	20/km
15	1	Length (9um)	C8	200	20km
16	1	Length	00	0	-
17	1	Length(62.5um)	00	0	-
18	1	Length(copper)	00	0	-
19	1	Reserved	00	0	-
20-35	16	Vendor name	5A2D 51 55 4943 4B 20 20 20 20 20 20 20 20 20	90 45 81 85 73 67 75 32 32 32 32 32 32 32 32 32	'SOPTO' (ASCII)
36	1	Reserved	00	0	-
37-39	3	Vendor OUI	00 00 00	0 0 0	-

40-55	16	Vendor PN	5A4C3534333230 39392D494353xx 20 20	907653525150 485757457367 83 xx 32 32	'EPON OLT SFP' (ASCII)
56-59	4	Vendor rev	30 30 30 20	48 48 48 32	“000”(ASCII)
60-61	2	Wavelength	05	05	1490
62	1	Reserved	00	0	-
63	1	CC BASE	-	-	Check sum of bytes 0
64	1	Reserved	00	0	
65	1	Options	1A	26	
66	1	BR, max	00	0	-
67	1	BR, min	00	0	-
68-83	16	Vendor SN	-	-	ASCI
84-91	8	Vendor date	-	-	Year (2 bytes), Month (2)
92	1	DDM Type	68	104	Internal Calibrated
93	1	Enhanced Option	B0	176	LOS, TX_FAULT and Alarm/warning
94	1	SFF-8472 Compliance	03	3	SFF-8472Rev 10.3
95	1	CC EXT	-	-	Check sum of bytes 64
96-255	160	Vendor spec			

Alarm and Warning Thresholds (SerialID A2H)

Parameter(Unit)	C Temp (°C)	Voltage (V)	Bias (mA)	TX Power (dBm)			RX Power (dBm)
High Alarm	100	3.6	90	+7	+7	+8	-6
Low Alarm	-10	3	0	+2.5	+3.5	+5	-30
High Warning	95	3.5	70	+6	+6	+7.5	-7
Low Warning	0	3.1	0	+3	+4	+6	-29

Digital Diagnostic Monitor Accuracy

Parameter	Unit	Accuracy	Range	Calibration
Tx Optical Power	dB	±3	Po: Pomin~Pomax dBm, Recommended	External/Intern al
Rx Optical Power	dB	±3	Pi: Ps~Pr dBm, Recommended operation	External/Intern al

Bias Current	%	±10	Id: 1-100mA, Recommended operating	External/Intern
Power Supply	%	±3	Recommended operating	External/Intern
Internal Temperature	°C	±3	Recommended operating	External/Intern

PIN Diagram

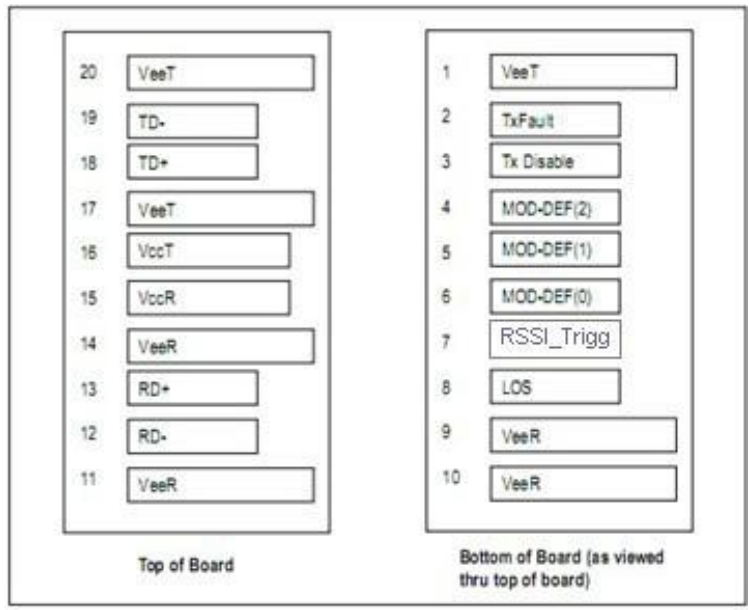

PIN Description

Pin No.	Name	Function	Plug Seq.	Notes
1	VeeT	Transmitter Ground	1	
2	Tx Fault	Transmitter Fault Indication	3	Note 1
3	Tx Disable	Transmitter Disable	3	Note 2
4	MOD-DEF2	Module Definition 2	3	Note 3
5	MOD-DEF1	Module Definition 1	3	Note 3
6	MOD-DEF0	Module Definition 0	3	Note 3
7	RSSI_Trigg	Receiver Signal Strength Indication	3	
8	LOS	Los Of Signal	3	Note 4
9	VeeR	Receiver Ground	1	Note 5
10	VeeR	Receiver Ground	1	Note 5
11	VeeR	Receiver Ground	1	Note 5
12	RD-	Inv. Receiver DataOut	3	Note6
13	RD+	Receiver Data Out	3	Note 6
14	VeeR	Receiver Ground	1	Note 5
15	VccR	Receiver Power Supply	2	Note 7, 3.3V±5%
16	VccT	Transmitter Power Supply	2	Note 7, 3.3V±5%
17	VeeT	Transmitter Ground	1	Note 5

18	TD+	Transmitter DataIn	3	Note8
19	TD-	Inv.Transmitter DataIn	3	Note8
20	VeeT	Transmitter Ground	1	Note 5

Notes:

- TX Fault is an open collector/drain output, which should be pulled up with a 4.7K–10KΩ resistor on the host board. Pull up voltage between 2.0V and VccT, R+0.3V. When high, output indicates a laser fault of some kind. Low indicates normal operation. In the low state, the output will be pulled to < 0.8V.
- TX disable is an input that is used to shut down the transmitter optical output. It is pulled up within the module with a 4.7–10 KΩ resistor. Its states are:
 Low (0 – 0.8V): Transmitter on
 (>0.8, < 2.0V): Undefined
 High (2.0 – 3.465V): Transmitter Disabled
 Open: Transmitter Disabled
- Mod-Def 0,1,2. These are the module definition pins. They should be pulled up with a 4.7K – 10KΩ resistor on the host board. The pull-up voltage shall be VccT or VccR.
 Mod-Def 0 is grounded by the module to indicate that the module is present
 Mod-Def 1 is the clock line of two wire serial interface for serial ID
 Mod-Def 2 is the data line of two wire serial interface for serial ID
- LOS (Loss of Signal) is an open collector/drain output, which should be pulled up with a 4.7K – 10KΩ resistor. Pull up voltage between 2.0V and VccT, R+0.3V. When high, this output indicates the received optical power is below the worst-case receiver sensitivity (as defined by the standard in use). Low indicates normal operation. In the low state, the output will be pulled to < 0.8V.
- VeeR and VeeT may be internally connected within the SFP module.
- RD-/+: These are the differential receiver outputs. They are DC coupled 100Ω differential lines which should be terminated with 100Ω (differential) at the user SERDES.
- VccR and VccT are the receiver and transmitter power supplies. They are defined as 3.3V ±5% at the SFP connector pin. Maximum supply current is 450mA. Recommended host board power supply filtering is shown below. Inductors with DC resistance of less than 1Ω should be used in order to maintain the required voltage at the SFP input pin with 3.3V supply voltage. When the recommended supply filtering network is used, hot plugging of the SFP transceiver module will result in an inrush current of no more than 30 mA greater than the steady state value. VccR and VccT may be internally connected within the SFP transceiver module.
- TD-/+: These are the differential transmitter inputs. They are AC-coupled, differential lines with 100Ω differential termination inside the module. The AC coupling is done inside the module and is thus not required on the host board.

Package Diagram

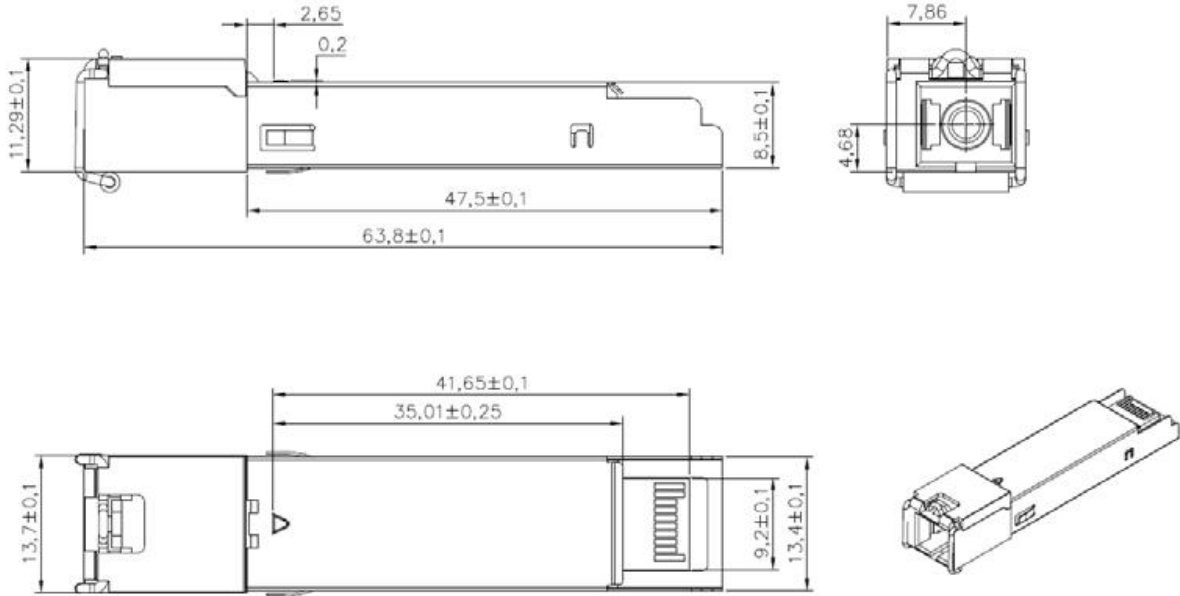

Unit:mm

Recommended Circuit

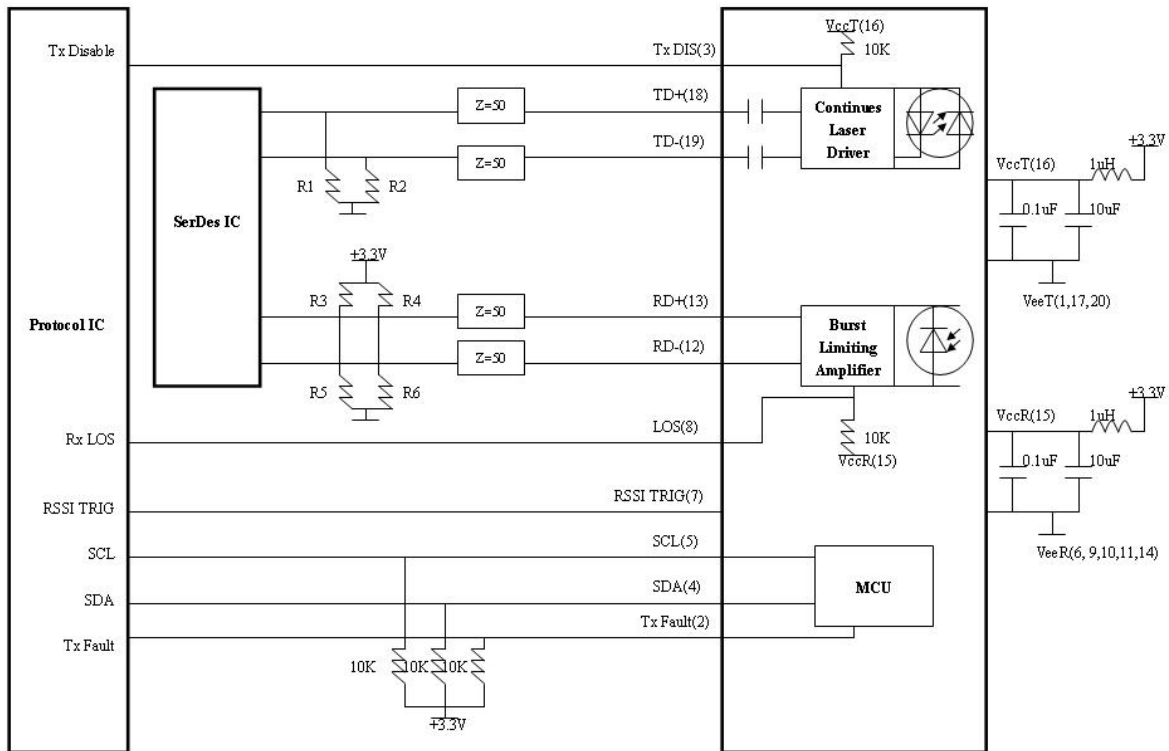

Note:

Tx : AC coupled internally.

R1=R2=150Ω.

Rx : LVPECL output, DC coupled internally.

Input stage in SerDes IC with internal bias to Vcc-1.3V R3=R4=R5=R6=N.C

Input stage in SerDes IC without internal bias to Vcc-1.3V

R3=R4=130Ω, R5=R6=82Ω.

Timing Parameter Definition

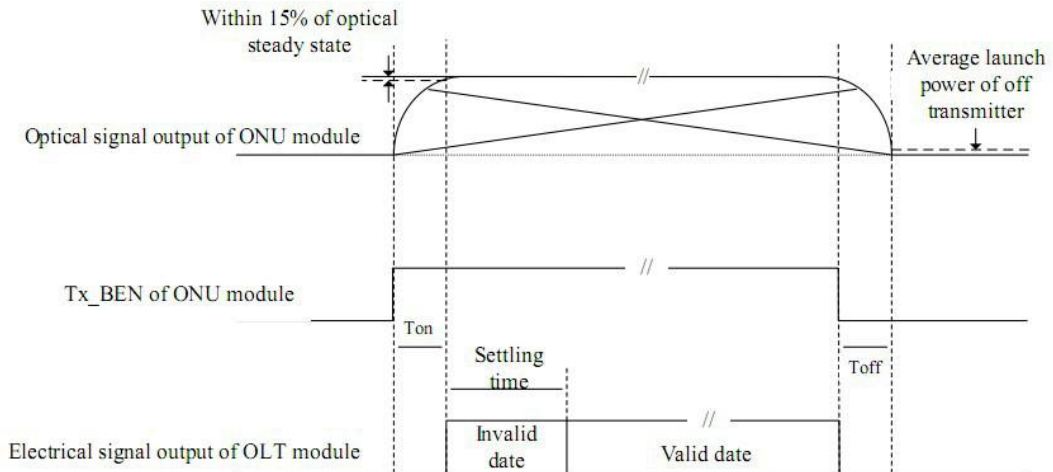

Figure1 Time parameter definition in EPON system

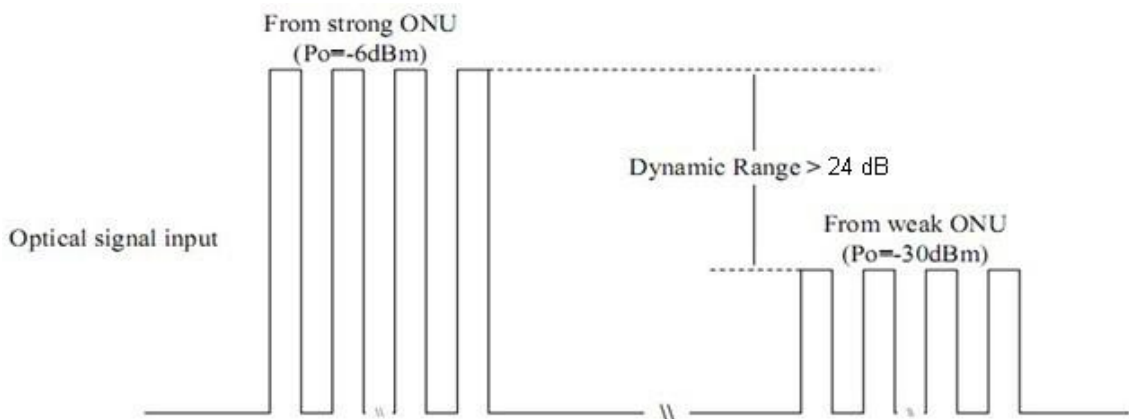
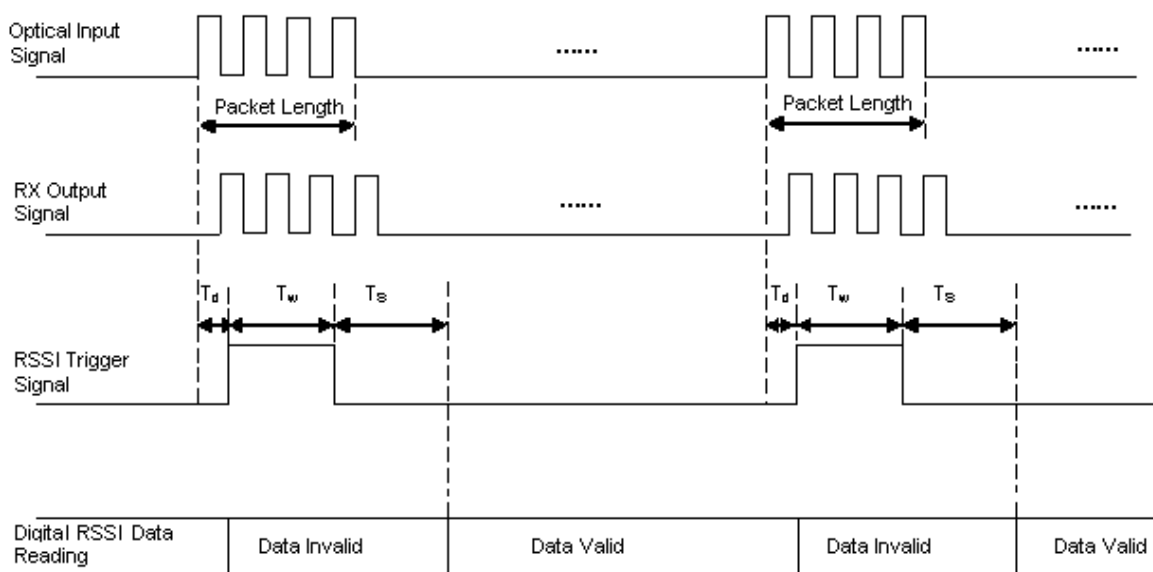

Figure2 Burst_mode Receiver Dynamic range in EPON system

Timing Of Digital RSSI





PARAMETER	SYMBOL	MIN	TYP	MAX	UNITS
Packet Length	-	600	-	-	ns
Trigger delay	T _d	100	-	-	ns
RSSI Trigger and Sample Time	T _w	500	-	-	ns
Internal delay	T _s	500	-	-	us

Ordering information

Part Number	Product Description
SPT-ET4311-SE2BD	Transceiver EPON OLT SFP 1490nm/1310nm 1.25G Tx/1.25G Rx SC Interface 1000BASE-PX20 with DDM Commercial Temperature
SPT-ET4311-SE2AD	Transceiver EPON OLT SFP 1490nm/1310nm 1.25G Tx/1.25G Rx SC Interface 1000BASE-PX20+ with DDM Commercial Temperature
SPT-ET4311-SE2CD	Transceiver EPON OLT SFP 1490nm/1310nm 1.25G Tx/1.25G Rx SC Interface 1000BASE-PX20++ with DDM Commercial Temperature

Note: If you need more customized services, please contact us.

E-mail: info@sopto.com.cn

Web : <http://www.sopto.com.cn>