

SPT-P2T13V3-02D

3Gbps Video SFP Optical Transmitter, 2km Reach

Features

- HD-SDI SFP Transceiver available
- SD-SDI SFP Transceiver available
- 3G-SDI SFP Transceiver available
- SMPTE 297-2006 Compatible.
- Metal enclosure for Lower EMI
- 1310nm FP laser and PIN photo detector
- Supports video pathological patterns for SD-SDI, HD-SDI and 3G-SDI
- Compliant with SFP MSA and SFF-8472 with duplex LC receptacle
- Digital Diagnostic functions available through the I2C interface
- Compatible with RoHS
- +3.3V single power supply
- Operating case temperature: Standard: 0 to +70°C
Industrial: -40 to 85°C

Applications

- SMPTE 297-2006 Compatible Electrical-to-Optical Interfaces.
- HDTV/SDTV Service Interfaces.

Description

The video series transceivers are high performance, cost effective modules for duplex video transmission application over single mode fiber.

The Transmitter is designed to transmit data rates from 50Mbps to 2.97Gbps and is specifically designed for robust performance in the presence of SDI pathological patterns for SMPTE 259M, SMPTE 344M, SMPTE 292M and SMPTE 424M serial rates. The module is fully compliant with SMPTE 297M-2006.

The transmitter is a dual channel optical transmitter module, one channel consists of two sections: a FP laser transmitter and MCU control unit. All modules satisfy class I laser safety requirements.

Absolute Maximum

These values represent the damage threshold of the module. Stress in excess of any of the individual Absolute Maximum Ratings can cause immediate catastrophic damage to the module even if all other parameters are within Recommended Operating Conditions.

Parameter	Symbol	Min.	Max.	Units
Power Supply Voltage	Vcc	-0.5	4.5	V
Storage Temperature	Tc	-40	+85	°C
Relative Humidity	RH	5	85	%

Recommended Operating

Parameter		Symbol	Min	Typical	Max	Unit
Operating Case Temperature	Standard	Tc	0		+70	°C
	Industrial		-40		85	°C
Power Supply Voltage		Vcc	3.13	3.3	3.47	V
Power Supply Current		Icc			500	mA
Data Rate				3		Gbps

Optical and Electrical

Parameter	Symbol	Min	Typical	Max	Unit	Notes		
Transmitter								
Centre Wavelength	λ_c	1260	1310	1360	nm			
Spectral Width (-20dB)	σ			1	nm			
Side Mode Suppression Ratio	SMSR	30			dB			
Average Output Power	Pout	-8	-3	0	dBm	1		
Extinction Ratio	ER	5	8		dB			
Rise/Fall Time (20%~80%)	SD-SDI	tr/tf			1500	ps	2	
	HD-SDI				270			
	3G-SDI				135			
Total Output Jitter	PRBS and color bar				70	ps		
					HD-SDI			50
					3G-SDI			70
	Pathological				SD-SDI			200
					HD-SDI			115
					3G-SDI			120
Data Input Swing Differential	V _{IN}	400		1800	mV	3		
Input Differential Impedance	Z _{IN}	90	100	110	Ω			
TX Disable	Disable		2.0		Vcc	V		

	Enable		0		0.8	V	
TX Fault	Fault		2.0		Vcc	V	
	Normal		0		0.8	V	

Notes:

1. Rise and fall times, 20% to 80%, are measured following a fourth-order Bessel-Thompson filter with a bandwidth of 0.75 x clock frequency corresponding to the serial data rate.
2. PECL input, internally AC-coupled and terminated.
3. Internally AC-coupled

Timing and Electrical

Parameter	Symbol	Min	Typical	Max	Unit
Tx Disable Negate Time	t_on			1	ms
Tx Disable Assert Time	t_off			10	μs
Time To Initialize, including Reset of Tx Fault	t_init			300	ms
Tx Fault Assert Time	t_fault			100	μs
Tx Disable To Reset	t_reset	10			μs
Serial ID Clock Rate	f_serial_clock			280	KHz
MOD_DEF (0:2)-High	VH	2		Vcc	V
MOD_DEF (0:2)-Low	VL			0.8	V

Diagnostics

Parameter	Range	Unit	Accuracy	Calibration
Temperature	0 to +70	°C	±3°C	Internal / External
Voltage	3.0 to 3.6	V	±3%	Internal / External
Bias Current	0 to 100	mA	±10%	Internal / External
TX Power	-5 to 0	dBm	±3dB	Internal / External

I2C Bus

The I2C bus interface uses the 2-wire serial CMOS E2PROM protocol. The serial interface meets the following specifications:

1. Support a maximum clock rate of 280Khz.
2. Input/Output levels comply with LVCMOS/LVTTL or compatible logics.

Low: 0 – 0.8 V

High: 2.0 – 3.3 V

Undefined: 0.8 – 2.0 V

Pin

Pin Diagram

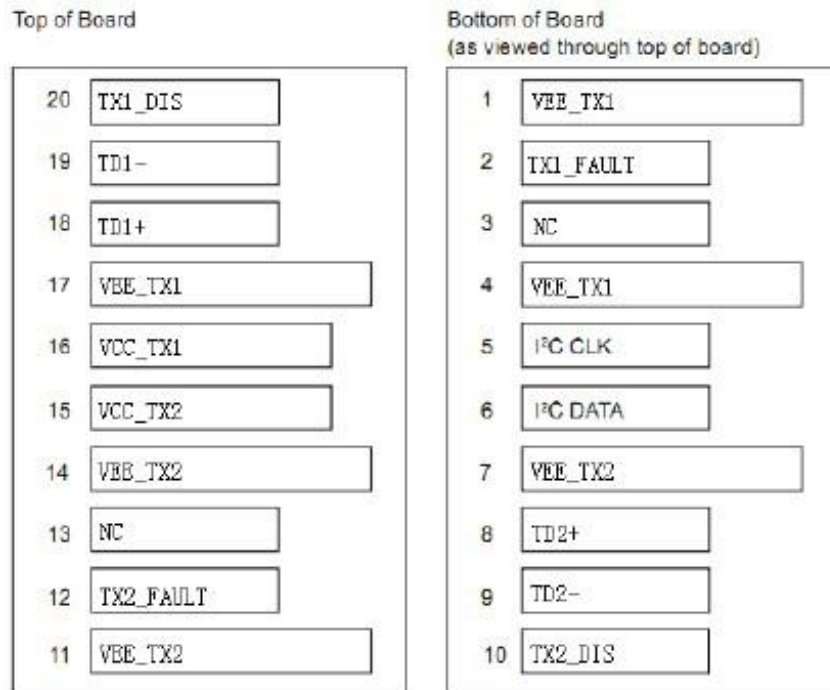

Pin Descriptions

Pin	Signal Name	Description	Plug Seq.	Notes
1	VEE_TX1	Transmitter 1 Ground	1	
2	TX1_FAULT	Transmitter 1 Fault Indication	3	Note 1
3	NC	Not Connected	3	
4	VEE_TX1	Transmitter 1 Ground	3	
5	I ² C CLK	SCL Serial Clock Signal	3	Note 3
6	I ² C DATA	SDA Serial Data Signal	3	Note 3
7	VEE_TX2	Transmitter 2 Ground	3	
8	TD2+	Transmit 2 Data In	3	Note 4
9	TD2-	Inv. Transmit 2 Data In	1	Note 4
10	TX2_DIS	Transmitter 2 Disable	1	Note 2
11	VEE_TX2	Transmitter 2 Ground	1	
12	TX2_FAULT	Transmitter 2 Fault Indication	3	Note 1
13	NC	Not Connected	3	
14	VEE_TX2	Transmitter 2 Ground	1	
15	VCC_TX2	Transmitter Power 2 Supply	2	
16	VCC_TX1	Transmitter Power 1 Supply	2	



17	VEE_TX1	Transmitter 1 Ground	1	
18	TD1+	Transmit 1 Data In	3	Note 4
19	TD1-	Inv. Transmit 1 Data In	3	Note 4
20	TX1_DIS	Transmitter 1 Disable	1	Note 2

Notes:

Plug Seq.: Pin engagement sequence during hot plugging.

1) TX Fault is an open collector output, which should be pulled up with a 4.7k~10kΩ resistor on the host board to a voltage between 2.0V and Vcc+0.3V. Logic 0 indicates normal operation; Logic 1 indicates a laser fault of some kind. In the low state, the output will be pulled to less than 0.8V.

2) TX Disable is an input that is used to shut down the transmitter optical output. It is pulled up within the module with a 4.7k~10kΩ resistor. Its states are:

Low (0 to 0.8V): Transmitter on

(>0.8V, < 2.0V): Undefined

High (2.0 to 3.465V): Transmitter Disabled

Open: Transmitter Disabled

3) Mod-Def. 0, 1, 2. These are the module definition pins. They should be pulled up with a 4.7k~10kΩ resistor on the host board.

The pull-up voltage shall be VccT or VccR.

Mod-Def. 0 is grounded by the module to indicate that the module is present

Mod-Def. 1 is the clock line of two wire serial interface for serial ID

Mod-Def. 2 is the data line of two wire serial interface for serial ID

4) LOS is an open collector output, which should be pulled up with a 4.7k~10kΩ resistor. Pull up voltage between 2.0V and Vcc and 0.3V. Logic 1 indicates loss of signal; Logic 0 indicates normal operation. In the low state, the output will be pulled to less than 0.8V.

5) RD-/+ : These are the differential receiver outputs. They are internally AC-coupled 100 differential lines which should be terminated with 100Ω (differential) at the user SERDES.

6) TD-/+ : These are the differential transmitter inputs. They are internally AC-coupled, differential lines with 100Ω differential termination inside the module.

Serial ID Field Memory

The module serial Id and calibration information is stored in the E2PROM of the SFP supervising device using the address map.

Byte Adder	Bit Size	Name	Description	Value (hex)
0	1	Identifier	Type of transceiver	82
1	1	Ext. Identifier	Extended identifier of type of transceiver	04
2	1	Connector	Code for connector type	07
3	1	Standards Compliance	For SMPTE259M/344M/292M/424M and SMPTE297M	41
4~10	7	Transceiver	Code for electronic or optical compatibility, Not applicable.	
11	1	Encoding	Code for serial encoding algorithm	30
12	1	BR, Nominal	Nominal signaling rate, units of 100MBd.	1E
13	1	Rate Identifier	Type of rate select functionality, Not applicable	
14	1	Length(SMF, km)	Link length supported for single mode fiber, units of km	14
15	1	Length (SMF)	Link length supported for single mode fiber, units of 100 m	00
16	1	Length (50um)	Link length supported for 50 um OM2 fiber, units of 10 m	00
17	1	Length (62.5um)	Link length supported for 62.5 um OM1 fiber, units of 10 m	00
18	1	Length (cable)	Link length supported for copper or direct attach cable, units of m	00
19	1	Length (OM3)	Link length supported for 50 um OM3 fiber, units of 10 m	00
20~35	16	Vendor name	SFP vendor name (ASCII)	X
36	1	Reserved	Reserved	00
37~39	3	Vendor OUI	SFP vendor IEEE company ID	0
40~55	16	Vendor PN	Part number provided by SFP vendor (ASCII)	X
56~59	4	Vendor rev	Revision level for part number provided by vendor (ASCII)	X
60	2	Wavelength	Laser wavelength (Passive/Active Cable Specification Compliance)	
61				
62	1	Unallocated		
63	1	CC_BASE	Check code for Base ID Fields	
64	2	Options	Indicates which optional transceiver signals are implemented	
65				

66	1	BR, max	Upper bit rate margin, units of%	05
67	1	BR, min	Lower bit rate margin, units of%	5F
68~84	16	Vendor SN	Serial number provided by vendor (ASCII)	X
85~91	8	Date code	Vendor's manufacturing date code	
92	1	Diagnostic Monitoring Type	Indicates which type of diagnostic monitoring is implemented(if any) in the transceiver	28
93	1	Enhanced Options	Indicates which optional enhanced features are implemented(if any) in the transceiver	90
94	1	SFF-8472 Compliance	Indicates which revision of SFF-8472 the transceiver complies with.	X
95	1	CC_EXT	Check code for the Extended ID Fields	
96~127	32	Vendor Specific	Vendor Specific EEPROM	0

Digital Diagnostic Monitoring Interface (2-Wire Address)

Byte Address	Bit Size	Name	Description and Value of the Field
00-01	2	Temp High Alarm	MSB at lower address. 100°C
02-03	2	Temp Low Alarm	MSB at lower address. -50°C
04-05	2	Temp High Warning	MSB at lower address. 95°C
06-07	2	Temp Low Warning	MSB at lower address. -45°C
08-09	2	Voltage High Alarm	MSB at lower address. 3.7V
10-11	2	Voltage Low Alarm	MSB at lower address. 2.9V
12-13	2	Voltage High Warning	MSB at lower address. 3.6V
14-15	2	Voltage Low Warning	MSB at lower address. 3.0V
16-17	2	Bias High Alarm	MSB at lower address. 70mA
18-19	2	Bias Low Alarm	MSB at lower address. 8mA
20-21	2	Bias High Warning	MSB at lower address. 65mA
22-23	2	Bias Low Warning	MSB at lower address. 9mA
24-25	2	TX Power High Alarm	MSB at lower address. -1dBm
26-27	2	TX Power Low Alarm	MSB at lower address. -10dBm
28-29	2	TX Power High Warning	MSB at lower address. 0dBm
30-31	2	TX Power Low Warning	MSB at lower address. -9dBm
32-33	2	RX Power High Alarm	MSB at lower address. 1dBm
34-35	2	RX Power Low Alarm	MSB at lower address. -25dBm
36-37	2	RX Power High Warning	MSB at lower address. 0dBm
38-39	2	RX Power Low Warning	MSB at lower address. -24dBm
40-55	16	Reserved	Reserved
56-59	4	RX_PWR (4)	Set to zero for "internally calibrated" devices, Values 00 00 00 00.
60-63	4	RX_PWR (3)	Set to zero for "internally calibrated" devices. Values 00 00 00 00.



64-67	4	RX_PWR (2)	Set to zero for “internally calibrated” devices. Values 00 00 00 00.
68-71	4	RX_PWR (1)	Set to 1 for “internally calibrated” devices. Value is 3F 80 00 00.
72-75	4	RX_PWR (0)	Set to zero for “internally calibrated” devices. Values 00 00 00 00.
76-77	2	TX_I (Slope)	Set to 1 for “internally calibrated” devices. Value is 01 00.
78-79	2	TX_I (Offset)	Set to zero for “internally calibrated” devices. Values 00 00.
80-81	2	TX_PWR (Slope)	Set to 1 for “internally calibrated” devices. Value is 01 00.
82-83	2	TX_PWR (Offset)	Set to zero for “internally calibrated” devices. Values 00 00.
84-85	2	T (Slope)	Set to 1 for “internally calibrated” devices. Value is 01 00.
86-87	2	T (Offset)	Set to zero for “internally calibrated” devices. Values 00 00.
88-89	2	V (Slope)	Set to 1 for “internally calibrated” devices. Value is 01 00.
90-91	2	V (Offset)	Set to zero for “internally calibrated” devices. Values 00 00.
92-94	3	Reserved	Reserved
95	1	Checksum	Checksum of bytes 0 – 94.
96-97	2	Temperature (MSB, LSB)	Internally measured module temperature
98-99	2	Supply Voltage (MSB, LSB)	internally measured supply voltage in module
100-101	2	Bias()(MSB, LSB)	Internally measured module bias
102-103	2	TX Power(MSB, LSB)	Internally measured TX Power Current
104-105	2	Rx Power (MSB, LSB)	Internally Measured Rx Power Current
106-109	4	Reserved	Reserved
110	Bit7	TX Disable State	Digital state of the TX Disable Input Pin.
110	Bit6	Soft TX Disable	Bit 6
110	Bit5-Bit3	Reserved	
110	Bit2	TX Fault	Bit 2
110	Bit1	LOS	Bit 1
110	Bit0	Data_Ready	Bit 0
111	1	Reserved	Reserved
112	Bit7	Temp High Alarm	Set when internal temperature exceeds High Alarm level.
112	Bit6	Temp Low Alarm	Set when internal temperature is below Low alarm level.
112	Bit5	Vcc High Alarm	Set when internal supply voltage exceeds High Alarm level.
112	Bit4	Vcc Low Alarm	Set when internal supply voltage is below Low Alarm level.

112	Bit3	TX Bias High Alarm	Set when TX Bias current exceeds high Alarm Level.
112	Bit2	TX Bias Low Alarm	Set when TX Bias current is below low Alarm Level.
112	Bit1	TX Power High Alarm	Set when TX output power exceeds high Alarm Level.
112	Bit0	TX Power Low Alarm	Set when TX output power is below low Alarm Level.
113	Bit7	RX Power High Alarm	Set when Received Power exceeds high Alarm Level.
113	Bit6	RX Power Low Alarm	Set when Received Power is below low Alarm Level.
113	Bit5-Bit0	Reserved Alarm	Reserved
114-115	Reserved		Reserved
116	Bit7	Temp High Warning	Set when internal temperature exceeds High Warning level.
116	Bit6	Temp Low Warning	Set when internal temperature is below Low Warning level.
116	Bit5	Vcc High Warning	Set when internal supply voltage exceeds High Warning level.
116	Bit4	Vcc Low Warning	Set when internal supply voltage is below Low Warning level.
116	Bit3	TX Bias High Warning	Set when TX Bias current exceeds high Warning Level.
116	Bit2	TX Bias Low Warning	Set when TX Bias current is below low Warning Level.
116	Bit1	TX Power High Warning	Set when TX output power exceeds high Warning Level.
116	Bit0	TX Power Low Warning	Set when TX output power is below low Warning Level.
117	Bit7	RX Power High Warning	Set when Received Power exceeds high Warning Level.
117	Bit6	RX Power Low Warning	Set when Received Power is below low Warning Level.
117	Bit5-bit0	Reserved Warning	Reserved
118-119	2	Reserved	Reserved
120-127	8	Vendor specific	
128-247	120	User EEPROM	User writable EEPROM
248-255	8	Vendor Specific	Vendor specific control functions

Mechanical Dimensions

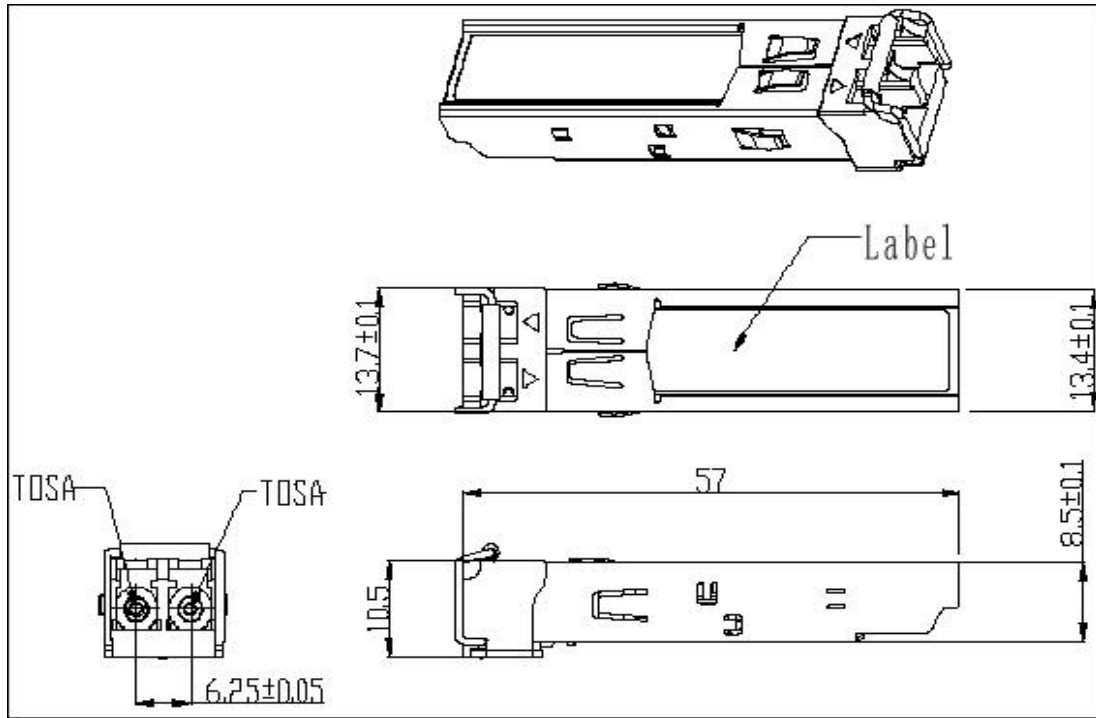

Unit:mm

Ordering information

Part Number	Product Description
SPT-P2T13V3-02D	3Gbps Video Dual Tx SFP, 1310nm, 2km, 0°C ~ +70°C, With DDM
SPT-P2T13V3-02TD	3Gbps Video Dual Tx SFP, 1310nm, 2km, -40 to 85°C, With DDM

Note: If you need more customized services, please contact us.

E-mail: info@sopto.com.cn

Web : <http://www.sopto.com.cn>