

# SPT-P1RV3-L40D

## 3Gbps Video SFP Optical Receiver, PIN photo detector

### Features

- HD-SDI SFP Receiver available
- SD-SDI SFP Receiver available
- 3G-SDI SFP Receiver available
- SMPTE 297-2006 Compatible.
- Metal enclosure for Lower EMI
- PIN photo detector
- Supports video pathological patterns for SD-SDI, HD-SDI and 3G-SDI
- Compliant with SFP MSA and SFF-8472 with duplex LC receptacle
- Digital Diagnostic functions available through the I2C interface
- Compatible with RoHS
- +3.3V single power supply
- Operating case temperature: Standard: 0 to +70°C
- Applications
- SMPTE 297-2006 Compatible Electrical-to-Optical Interfaces.
- HDTV/SDTV Service Interfaces.

### Description

The video series transceivers are high performance, cost effective modules for duplex video transmission application over single mode fiber.

The receiver is designed to receive data rates from 50Mbps to 2.97Gbps and is specifically designed for robust performance in the presence of SDI pathological patterns for SMPTE 259M, SMPTE 344M, SMPTE 292M and SMPTE 424M serial rates. The module is fully compliant with SMPTE 297M-2006.

The receiver is consists of a PIN photodiode integrated with a trans-impedance preamplifier (TIA) and MCU control unit. All modules satisfy class I laser safety requirements.

The MSA Type receivers are compatible with SFP Multi-Source Agreement (MSA) and SFF-8472. For further information, please refer to SFP MSA.

## Absolute Maximum Ratings

Parameter	Symbol	Min	Max	Unit
Supply Voltage	V <sub>cc</sub>	-0.5	4.5	V
Storage Temperature	T <sub>s</sub>	-40	+85	°C
Operating Humidity	-	5	85	%

## Recommended Operating Conditions

Parameter	Symbol	Min	Typical	Max	Unit
Operating Case Temperature	T <sub>c</sub>	0		+70	°C
Power Supply Voltage	V <sub>cc</sub>	3.13	3.3	3.47	V
Power Supply Current	I <sub>cc</sub>			150	mA
Data Rate			3		Gbps

## Optical and Electrical Characteristics

Parameter	Symbol	Min	Typical	Max	Unit	Notes
<b>Receiver</b>						
Rise/Fall Time (20%~80%)	SD-SDI			1500	ps	1
	HD-SDI			270		
	3G-SDI			135		
Total Output jitter	PRBS and cooler bar	SD-SDI	70	200	ps	
		HD-SDI	50	135		
		3G-SDI	70	100		
	pathological	SD-SDI	200	300		
		HD-SDI	115			
		3G-SDI	120			
Centre Wavelength	λ <sub>c</sub>	1260		1580	nm	
Receiver Sensitivity (PRBS)	SD-SDI			-22	dBm	
	HD-SDI			-22	dBm	
	3G-SDI			-22	dBm	
Receiver Sensitivity (Pathological)	SD-SDI			-20	dBm	
	HD-SDI			-22	dB	
	3G-SDI			-22	mV	
Receiver Overload		0			dBm	3
LOS De-Assert	LOS <sub>D</sub>			-20	dBm	
LOS Assert	LOS <sub>A</sub>	-30			dBm	
LOS Hysteresis		1		4	dB	
Data Output Swing Differential	V <sub>out</sub>	650	800	1000	mV	2
LOS	High	2.0		V <sub>cc</sub>	V	
	Low			0.8	V	

Notes:

1. Rise and fall times, 20% to 80%, are measured following a fourth-order Bessel-Thompson filter with a bandwidth of 0.75 x clock frequency corresponding to the serial data rate.
2. PECL input, internally AC-coupled and terminated.
3. Internally AC-coupled

## Timing and Electrical

Parameter	Symbol	Min	Typical	Max	Unit
LOS Assert Time	t_loss_on			100	μs
LOS De-assert Time	t_loss_off			100	μs
Serial ID Clock Rate	f_serial_clock			280	KHz
MOD_DEF (0:2)-High	V <sub>H</sub>	2		V <sub>cc</sub>	V
MOD_DEF (0:2)-Low	V <sub>L</sub>			0.8	V

## Diagnostics

Parameter	Range	Unit	Accuracy	Calibration
Temperature	0 to +70	°C	±3°C	Internal / External
Voltage	3.0 to 3.6	V	±3%	Internal / External
RX Power	-20 to -6	dBm	±3dB	Internal / External

### I2C Bus Interface

The I2C bus interface uses the 2-wire serial CMOS E2PROM protocol. The serial interface meets the following specifications:

1. Support a maximum clock rate of 280 KHz.
2. Input/output levels comply with LVCMOS/LVTTL or compatible logics.  
 Low: 0 – 0.8 V    High: 2.0 – 3.3 V    Undefined: 0.8 – 2.0 V

## Pin Definitions

### SFP MSA Type

## Top of Board

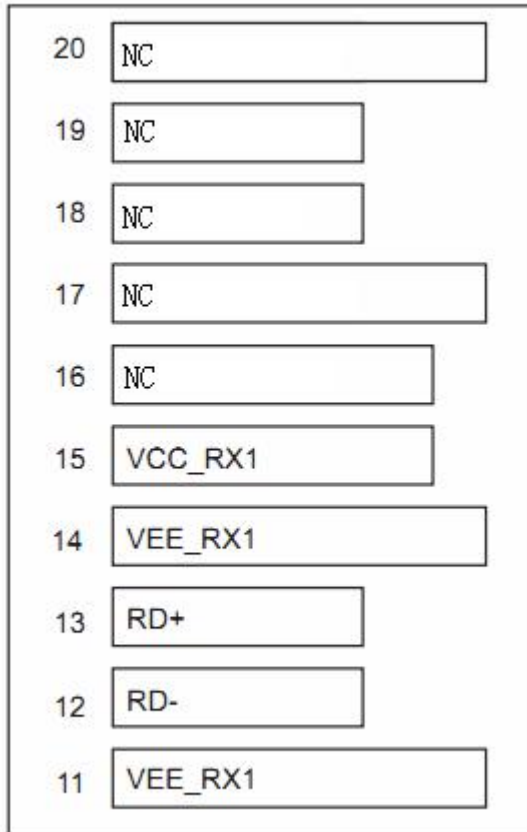
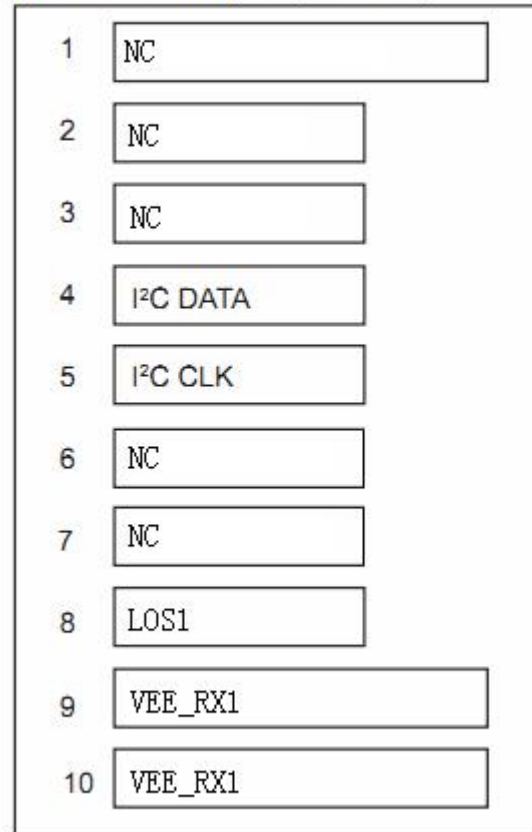
 Bottom of Board  
(as viewed through top of board)

### Pin Descriptions (SFP MSA Type)

Pin	Signal Name	Description	Plug Seq.	Notes
1	NC	Not Connected		
2	NC	Not Connected		
3	NC	Not Connected		
4	MOD_DEF(2)	SDA Serial Data Signal	3	Note 1
5	MOD_DEF(1)	SCL Serial Clock Signal	3	Note 1
6	NC	Not Connected		
7	NC	Not Connected		
8	LOS	Loss of Signal	3	Note 2
9	VEER	Receiver ground	1	
10	VEER	Receiver ground	1	
11	VEER	Receiver ground	1	
12	RD-	Inv. Received Data Out	3	Note 3
13	RD+	Received Data Out	3	Note 3
14	VEER	Receiver ground	1	
15	VCCR	Receiver Power Supply	2	
16	NC	Not Connected		
17	NC	Not Connected		
18	NC	Not Connected		

19	NC	Not Connected		
20	NC	Not Connected		

### Non Standard Type

Top of Board

20	NC
19	NC
18	NC
17	NC
16	NC
15	VCC_RX1
14	VEE_RX1
13	RD+
12	RD-
11	VEE_RX1

Bottom of Board

(as viewed through top of board)

1	NC
2	NC
3	NC
4	NC
5	I <sup>2</sup> C CLK
6	I <sup>2</sup> C DATA
7	VEE_RX1
8	LOS1
9	VEE_RX1
10	VEE_RX1

### Pin Descriptions (Not Standard Type)

Pin	Signal Name	Description	Plug Seq.	Notes
1	NC	Not Connected		
2	NC	Not Connected		
3	NC	Not Connected		
4	NC	Not Connected		
5	I2C CLK	SCL Serial Clock Signal	3	Note 1
6	I2C DATA	SDA Serial Data Signal	3	Note 1
7	VEE_RX1	Receiver1 Ground	3	
8	LOS1	Loss of Signal	3	Note 2
9	VEE_RX1	Receiver1 Ground	1	
10	VEE_RX1	Receiver1 ground	1	
11	VEE_RX1	Receiver1 ground	1	
12	RD-	Inv. Received Data Out	3	Note 3
13	RD+	Received Data Out	3	Note 3

14	VEE_RX1	Receiver1 ground	1	
15	VCC_RX1	Receiver1 Power Supply	2	
16	NC	Not Connected		
17	NC	Not Connected		
18	NC	Not Connected		
19	NC	Not Connected		
20	NC	Not Connected		

**Notes:**

Plug Seq.: Pin engagement sequence during hot plugging.

1) These are the module definition pins. They should be pulled up with a 4.7k~10kΩ resistor on the host board. The pull-up voltage shall be VccR.

I2C CLK is the clock line of two wire serial interface for serial ID

I2C DATA is the data line of two wire serial interface for serial ID

2) LOS is an open collector output, which should be pulled up with a 4.7k~10kΩ resistor. Pull up voltage between 2.0V and Vcc and 0.3V. Logic 1 indicates loss of signal; Logic 0 indicates normal operation. In the low state, the output will be pulled to less than 0.8V.

3) RD-/+ : These are the differential receiver outputs. They are internally AC-coupled 100 differential lines which should be terminated with 100Ω (differential) at the user SERDES.

## Serial ID Field Memory Map

The module serial Id and calibration information is stored in the E2PROM of the SFP supervising device using the address map.

Byte Adder	Bit Size	Name	Description	Value(hex)
0	1	Identifier	Type of transceiver	82
1	1	Ext. Identifier	Extended identifier of type of transceiver	04
2	1	Connector	Code for connector type	07
3	1	Standards Compliance	For SMPTE259M/344M/292M/424M and SMPTE297M	41
4-10	7	Transceiver	Code for electronic or optical compatibility, Not applicable.	
11	1	Encoding	Code for serial encoding algorithm	30
12	1	BR, Nominal	Nominal signaling rate, units of 100MBd.	1E
13	1	Rate Identifier	Type of rate select functionality, Not applicable	
14	1	Length(SMF, km)	Link length supported for single mode fiber, units of km	14
15	1	Length (SMF)	Link length supported for single mode fiber, units of 100 m	00
16	1	Length (50um)	Link length supported for 50 um OM2 fiber, units of 10 m	00
17	1	Length (62.5um)	Link length supported for 62.5 um OM1 fiber, units of 10 m	00
18	1	Length (cable)	Link length supported for copper or direct attach cable, units of m	00

19	1	Length (OM3)	Link length supported for 50 um OM3 fiber, units of 10 m	00
20-35	16	Vendor name	SFP vendor name (ASCII)	X
36	1	Reserved	Reserved	00
37	3	Vendor OUI	SFP vendor IEEE company ID	00
38				
39				
40-55	16	Vendor PN	Part number provided by SFP vendor (ASCII)	X
56	4	Vendor rev	Revision level for part number provided by vendor (ASCII)	X
57				
58				
59				
60	2	Wavelength	Laser wavelength (Passive/Active Cable Specification Compliance)	
61				
62	1	Unallocated		
63	1	CC_BASE	Check code for Base ID Fields	
64	2	Options	Indicates which optional transceiver signals are implemented	
65				
66	1	BR, max	Upper bit rate margin, units of%	05
67	1	BR, min	Lower bit rate margin, units of%	5F
68-83	16	Vendor SN	Serial number provided by vendor (ASCII)	X
84				
85-91	8	Date code	Vendor's manufacturing date code	
92	1	Diagnostic Monitoring Type	Indicates which type of diagnostic monitoring is implemented(if any) in the transceiver	28
93	1	Enhanced Options	Indicates which optional enhanced features are implemented(if any) in the transceiver	90
94	1	SFF-8472Compliance	Indicates which revision of SFF-8472 the transceiver complies with.	X
95	1	CC_EXT	Check code for the Extended ID Fields	
96-127	32	Vendor Specific	Vendor Specific EEPROM	0

## Digital Diagnostic Monitoring Interface (2-Wire Address A2H)

Byte	Addr	Bit	Size	Name	Description and Value of the Field
00-01		2		Temp High Alarm	MSB at lower address. 100°C
02-03		2		Temp Low Alarm	MSB at lower address. -50°C
04-05		2		Temp High Warning	MSB at lower address. 95°C
06-07		2		Temp Low Warning	MSB at lower address. -45°C

08-09	2	Voltage High Alarm	MSB at lower address. 3.7V
10-11	2	Voltage Low Alarm	MSB at lower address. 2.9V
12-13	2	Voltage High Warning	MSB at lower address. 3.6V
14-15	2	Voltage Low Warning	MSB at lower address. 3.0V
16-17	2	Bias High Alarm	MSB at lower address. 70mA
18-19	2	Bias Low Alarm	MSB at lower address. 8mA
20-21	2	Bias High Warning	MSB at lower address. 65mA
22-23	2	Bias Low Warning	MSB at lower address. 9mA
24-25	2		
26-27	2		
28-29	2		
30-31	2		
32-33	2	RX Power High Alarm	MSB at lower address. 1dBm
34-35	2	RX Power Low Alarm	MSB at lower address. -25dBm
36-37	2	RX Power High Warning	MSB at lower address. 0dBm
38-39	2	RX Power Low Warning	MSB at lower address. -24dBm
40-55	16	Reserved	Reserved
56-59	4		
60-63	4		
64-67	4		
68-71	4		
72-75	4		
76-77	2	TX_I (Slope)	Set to 1 for “internally calibrated” Devices. Value is 01 00.
78-79	2	TX_I (Offset)	Set to zero for “internally calibrated” Devices. Value is 00 00.
80-81	2	TX_PWR (Slope)	Set to 1 for “internally calibrated” Devices. Value is 01 00.
82-83	2	TX_PWR (Offset)	Set to zero for “internally calibrated” Devices. Value is 00 00.
84-85	2	T (Slope)	Set to 1 for “internally calibrated” Devices. Value is 01 00.
86-87	2	T (Offset)	Set to zero for “internally calibrated” Devices. Value is 00 00.
88-89	2	V (Slope)	Set to 1 for “internally calibrated” Devices. Value is 01 00.
90-91	2	V (Offset)	Set to zero for “internally calibrated” Devices. Value is 00 00.
92-94	3	Reserved	Reserved
95	1	Checksum	Checksum of bytes 0 – 94.
96-97	2	Temperature (MSB, LSB)	Internally measured module temperature
98-99	2	Supply Voltage (MSB, LSB)	internally measured supply voltage in module



100-101	2	Bias1()(MSB, LSB)	Internally measured module bias 1
102-103	2	Tx1 Power(MSB, LSB)	Internally measured Tx1 Power Current
104-105	2	Tx2 Power (MSB, LSB)	Internally Measured Tx2 Power Current
106-107	2	Bias2()(MSB, LSB)	Internally measured module bias2
108-109	2	Reserved	Reserved
110	Bit7	TX Disable State	Digital state of the TX Disable Input Pin.
110	Bit6	Soft TX Disable	Bit 6
110	Bit5-Bit3	Reserved	
110	Bit2	TX Fault	Bit 2
110	Bit1		Bit1
110	Bit0	Data_Ready	Bit 0
111	1	Reserved	Reserved
112	1		
113	1		
114-115	Reserved		Reserved
116	1		
117	1		
118-119	2	Reserved	Reserved
120-127	8	Vendor specific	
128-247	120	User EEPROM	User writable EEPROM
248-255	8	Vendor Specific	Vendor specific control functions

## Mechanical Dimensions

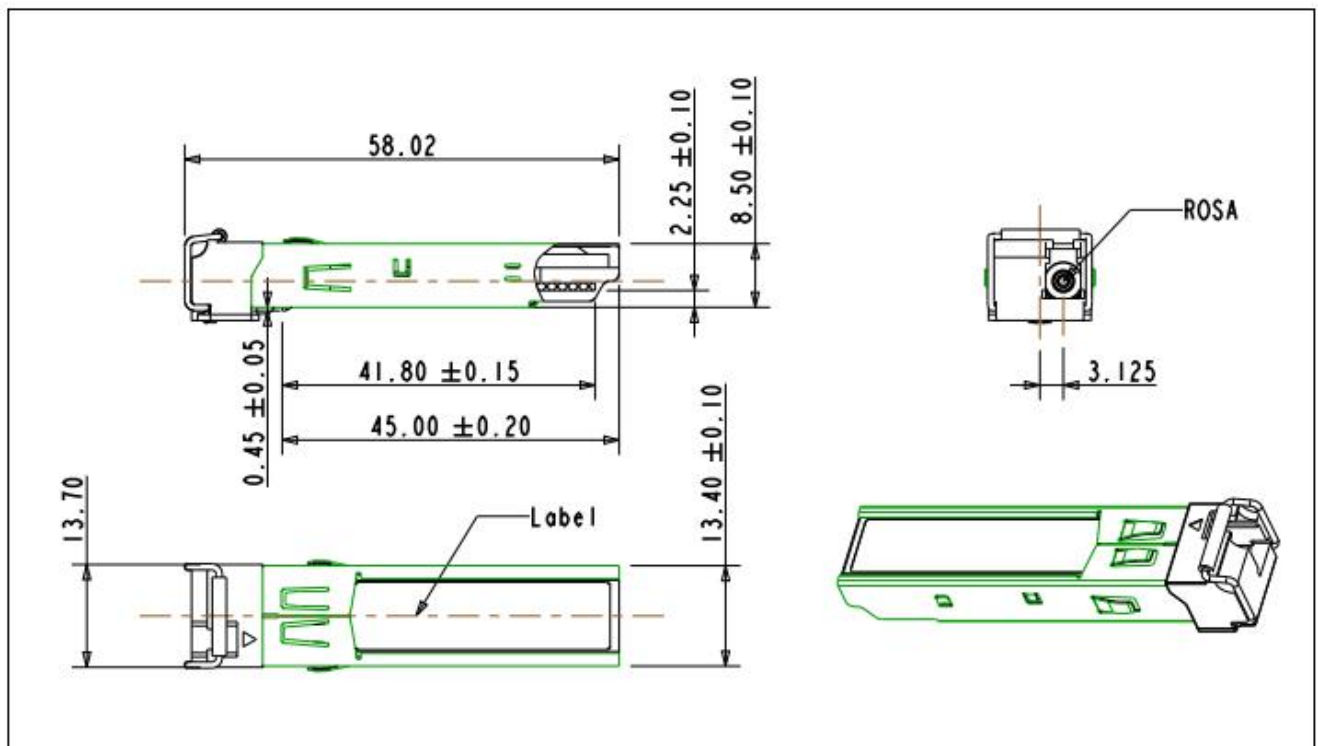

Unit:mm

## Ordering information

Part Number	Product Description	Notes
SPT-P1RV3-L40D	PIN, 3Gbps, Video Single Rx SFP, up to 40km, LC, 0°C ~ +70°C, With Digital Diagnostic Monitoring	SFP MSA Type or Non Standard Type

E-mail: [info@sopto.com.cn](mailto:info@sopto.com.cn)

Web : <http://www.sopto.com.cn>