

SPT-SFP28-LR(T)

25Gb/s SFP 28 1310nm Optical Transceiver, 10km

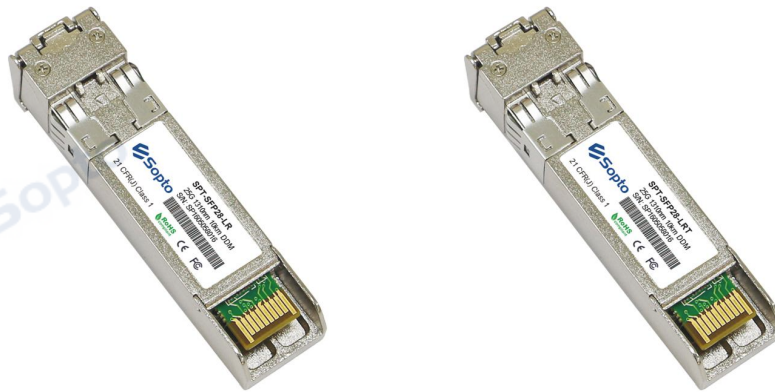

Features

- Supports 24.3Gb/s to 26.5Gb/s bit rates
- Up to 10km transmission on SMF
- DFB Laser and PIN Receiver
- 2-wire interface for management specifications compliant with SFF 8472 digital diagnostic monitoring interface for optical transceivers
- Single 3.3V power supply
- Power dissipation<1.2W
- Operating case temperature:
 - Commercial: 0 °C to +70°C
 - Industrial: -40 °C to +85°C
- Advanced firmware allow customer system encryption information to be stored in transceiver
- Cost effective SFP28 solution, enables higher port densities and greater bandwidth

Applications

- 25GBASE-LR Ethernet
- CPRI Option 10

Standard

- Compliant to SFF-8431
- Compliant to SFF-8472
- Compliant to IEEE 802.3CC

- RoHS compliant

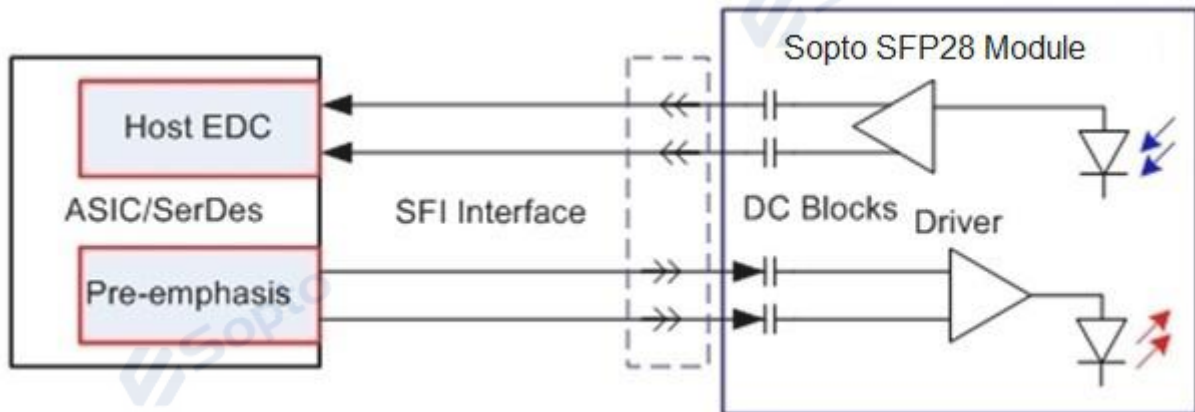

Figure1: Application in System

Description

SOPTO 1310 nm DFB 25 Gigabit SFP28 transceiver is designed to transmit and receive optical data over single mode optical fiber for link length 10km.

The SFP28 LR module electrical interface is compliant to SFI electrical specifications. The transmitter input and receiver output impedance is 100 Ohms differential. Data lines are internally AC coupled. The module provides differential termination and reduce differential to common mode conversion for quality signal termination and low EMI. SFI typically operates over 200 mm of improved FR4 material or up to about 150mm of standard FR4 with one connector.

The transmitter converts 25Gbit/s serial PECL or CML electrical data into serial optical data compliant with the 25GBASE-LR standard. An open collector compatible Transmit Disable (Tx_Dis) is provided. Logic “1” or no connection on this pin will disable the laser from transmitting. Logic “0” on this pin provides normal operation. The transmitter has an internal automatic power control loop (APC) to ensure constant optical power output across supply voltage and temperature variations. An open collector compatible Transmit Fault (Tx_Fault) is provided. TX_Fault is module output contact that when high, indicates that the module transmitter has detected a fault condition related to laser operation or safety. The TX_Fault output contact is an open drain/collector and shall be pulled up to the Vcc_Host in the host with a resistor in the range 4.7-10 kΩ. TX_Disable is a module input contact. When TX_Disable is asserted high or left open, the SFP28 module transmitter output shall be turned off. This contact shall be pulled up to VccT with a 4.7 kΩ to 10 kΩ resistor

The receiver converts 25Gbit/s serial optical data into serial PECL/CML electrical data. An open collector compatible Loss of Signal is provided. Rx_LOS when high indicates an optical signal level below that specified in the relevant standard. The Rx_LOS contact is an open drain/collector output and shall be pulled up to Vcc_Host in the host with a resistor in the range 4.7-10 kΩ, or with an active termination. Power supply filtering is recommended for both the transmitter and receiver. The Rx_LOS signal is intended as a preliminary indication to the system in which the SFP28 is installed that the received signal strength is below the specified range. Such an indication typically points to non-installed cables, broken cables, or a disabled, failing or a powered off transmitter at the far end of the cable.

Proposed Application Schematics

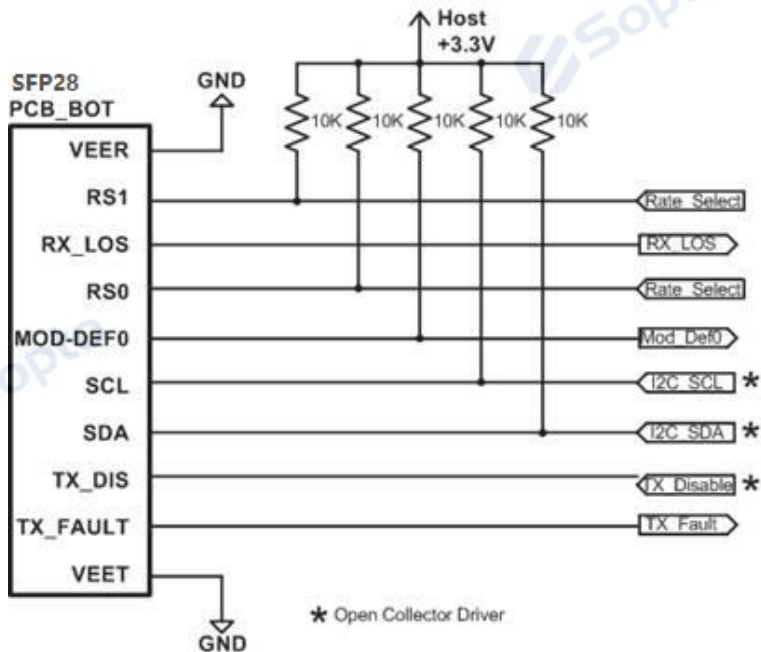
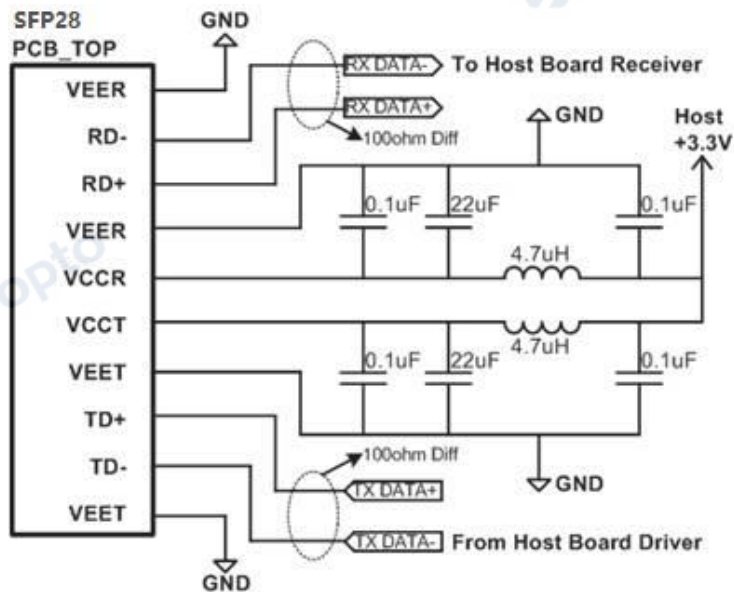

Absolute Maximum Ratings

These values represent the damage threshold of the module. Stress in excess of any of the individual Absolute Maximum Ratings can cause immediate catastrophic damage to the module even if all other parameters are within Recommended Operating Conditions.

Parameters	Symbol	Min.	Max.	Unit
Power Supply Voltage	VCC	0	3.6	V

Storage Temperature	Tc	-40	85	°C
Operating Case Temperature	Tc	0	70	°C
Relative Humidity	RH	5	95	%
Damage Threshold	Pmax	3.4		dBm

Recommended Operating Environment

Recommended Operating Environment specifies parameters for which the electrical and optical characteristics hold unless otherwise noted.

Parameters	Symbol	Min.	Typical	Max	Unit
Power Supply Voltage	VCC	3.135	3.3	3.465	V
Power Supply Current	Icc			300	mA
Operating Case Temperature	TC	0	25	70	°C

Optical Characteristics

The following optical characteristics are defined over the Recommended Operating Environment unless otherwise specified.

Parameter	Symbol	Min.	Typical	Max	Unit	Notes
Transmitter						
Center Wavelength	λ_t	1295		1325	nm	
Side Mode Suppression Ratio	SMSR	30			dB	
Average Optical Power	Pavg	-5		2	dBm	Note1
Laser Off Power	Poff			-30	dBm	
Extinction Ratio	ER	3.5			dB	
Transmitter Dispersion Penalty	TDP			2.7	dB	
Relative Intensity Noise	RIN20OMA			-130	dB/Hz	
Optical Modulation Amplitude	OMA	-2			dBm	
Receiver						
Center Wavelength	λ_r	1260		1350	nm	
Sensitivity (Average power)	Psens	-13.3		2	dBm	BER = 1×10^{-12}

Unstressed receiver sensitivity(OMA)	Psens			-13	dBm	BER = 1×10^{-6}
LOS Assert	LOSA			-13	dBm	
LOS De-assert	LOSD			-12	dBm	
LOS Hysteresis	LOSH	0.5			dB	
Return loss of receiver		26			dB	
Average received power (overload)				2	dBm	Note2

Notes:

[1]. Average optical power shall be measured using the methods specified in TIA/EIA-455-95.

[2]. Maximum average received power is compatible with FC-PI-6-32G while typical BER is less than 1×10^{-12} .

Electrical Characteristics

The following electrical characteristics are defined over the Recommended Operating Environment unless otherwise specified.

Parameter	Symbol	Min	Typical	Max	Unit	Notes
Data Rate		-	25.78	-	Gbps	
Power Consumption impedance		-	900	1000	mW	
Transmitter						
Single Ended Input Voltage Tolerance		-0.3			V	
AC Common mode voltage tolerance Voltage		15			mV	RMS
Differential Input Voltage Swing	V _{in}	180		700	mV	
Differential Input Impedance	Z _{in}	90	100	110	Ohm	
Receiver						
Single-ended Output Voltage		-0.3	-	4	V	
Differential Output Voltage Swing	V _o	300		850	Mv	
AC Common Mode Output Voltage				7.5	mV	RMS
Differential Output Impedance	Z _{out}	90	100	110	Ohm	

Pin Assignment

The SFP28 modules are hot-pluggable. Hot pluggable refers to plugging in or unplugging a module while the host board is powered. The SFP28 host connector is a 0.8 mm pitch 20 position right angle improved connector specified by SFF-8083, or stacked connector with equivalent with equivalent electrical performance. Host PCB contact assignment is shown in Figure 3 and contact definitions are given in the PIN description table. SFP28 module contacts mates with the host in the order of ground, power, followed by signal as illustrated by Figure 4 and the contact sequence order listed in the PIN description table.

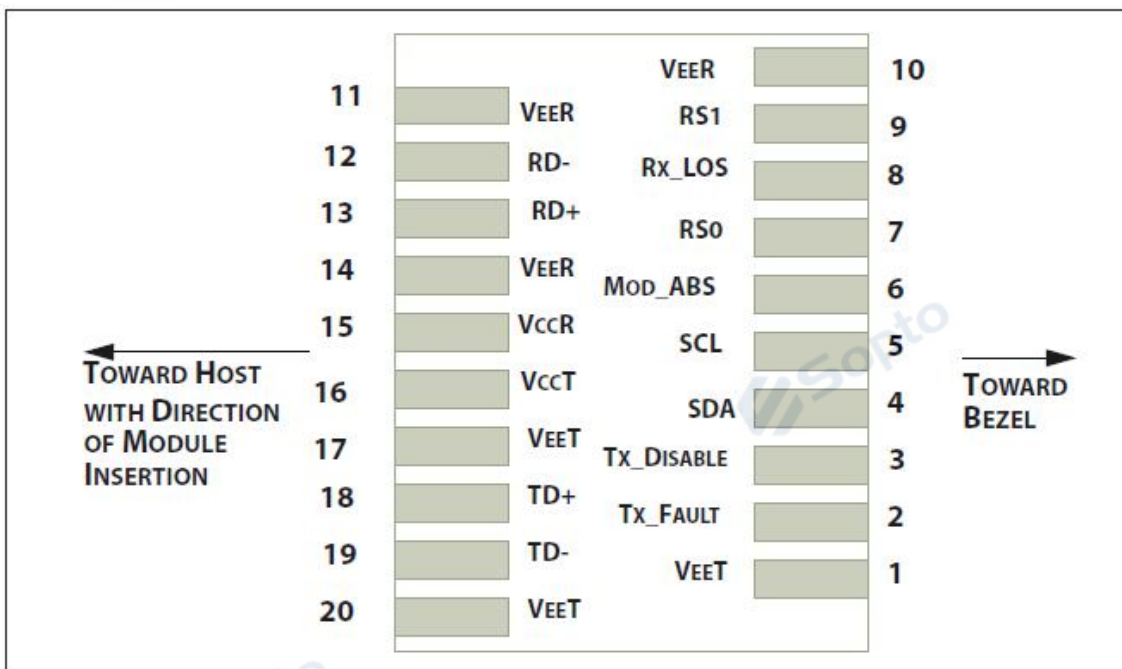

Module Contact Assignment

Figure 3:

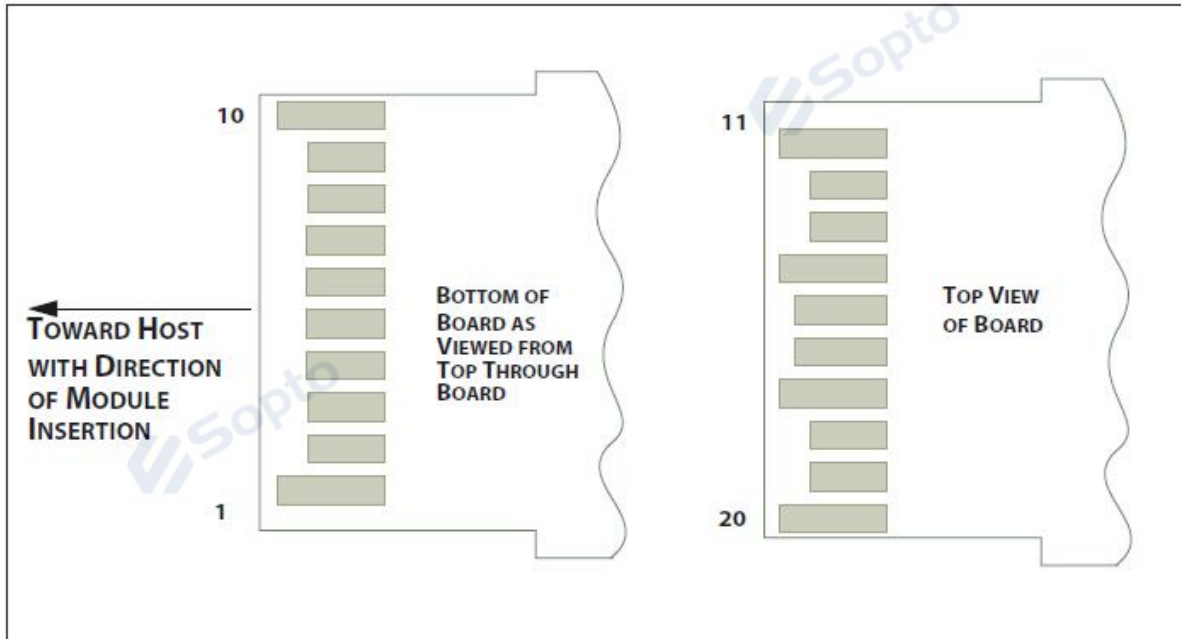

Figure 4: Module Contact Assignment

PIN description

PIN	Logic	Symbol	Name / Description	Note
1		VeeT	Module Transmitter Ground	1
2	LVTTL-O	TX_Fault	Module Transmitter Fault	
3	LVTTL-I	TX_Dis	Transmitter Disable; Turns off transmitter laser output	
4	LVTTL-I/O	SDA	2-Wire Serial Interface Data Line	2
5	LVTTL-I	SCL	2-Wire Serial Interface Clock	2
6		MOD_DEF0	Module Definition, Grounded in the module	
7	LVTTL-I	RS0	Receiver Rate Select	
8	LVTTL-O	RX_LOS	Receiver Loss of Signal Indication Active LOW	
9	LVTTL-I	RS1	Transmitter Rate Select (not used)	
10		VeeR	Module Receiver Ground	1
11		VeeR	Module Receiver Ground	1
12	CML-O	RD-	Receiver Inverted Data Output	
13	CML-O	RD+	Receiver Data Output	
14		VeeR	Module Receiver Ground	1
15		VccR	Module Receiver 3.3 V Supply	
16		VccT	Module Receiver 3.3 V Supply	
17		VeeT	Module Transmitter Ground	1
18	CML-I	TD+	Transmitter Non-Inverted Data Input	
19	CML-I	TD-	Transmitter Inverted Data Input	
20		VeeT	Module Transmitter Ground	1

Notes:

1. Module ground pins GND are isolated from the module case.
2. Shall be pulled up with 4.7K-10Kohms to a voltage between 3.15V and 3.45V on the host board.

Transceiver Block Diagram

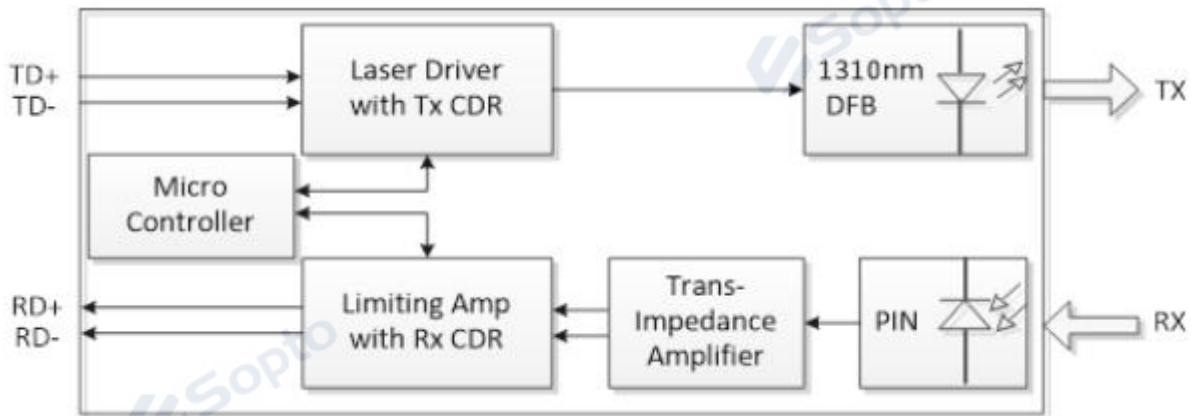

Digital Diagnostic Functions

The following digital diagnostic characteristics are defined over the Recommended Operating Environment unless otherwise specified. It is compliant to SFF8472 Rev11 with internal calibration mode. For external calibration mode please contact our sales

Parameter	Symbol	Min	Max	Unit	Notes
Temperature monitor absolute error	DMI_Temp	-3	3	DegC	Over operating temp
Laser power monitor absolute error	DMI_TX	-3	3	dB	
RX power monitor absolute error	DMI_RX	-3	3	dB	3.5dBm to -10.4dBm range
Supply voltage monitor absolute error	DMI_VCC	-0.1	3	V	Full operating range
Bias current monitor	DMI_Ibias	-10%	0.1	mA	

Control and Status I/O Timing Characteristics

Timing characteristics of control and status I/O are compatible with SFF-8431-MSA.

Parameter	Symbol	Min.	Max.	Unit	Conditions
Tx_Disable assert time	t_off		100	μs	Rising edge of Tx_Disable to fall of output signal below 10% of nominal
Tx_Disable negate time	t_on		2	ms	Falling edge of Tx_Disable to rise of output signal above 90% of nominal. This only applies in normal operation, not during start up or fault recovery.
Time to initialize 2-wire interface	t_2w_start_up		300	ms	From power on or hot plug after the supply meeting SFF8431
Time to initialize	t_start_up		300	ms	From power supplies meeting SFF8431 or hot plug or Tx disable negated during power up, or Tx_Fault recovery, until non-cooled power level I part (or non-cooled power level II part already enabled at power level II for Tx_Fault recovery) is fully operational.
Time to initialize cooled module and time to power up a cooled module to Power Level II	t_start_up_cooled		90	s	From power supplies meeting SFF8431 or hot plug, or Tx disable negated during power up or Tx_Fault recovery, until cooled power level I part (or cooled power level II part during fault recovery) is fully operational. Also, from stop bit low-to-high SDA transition enabling Power Level II until cooled module is fully operational.
Time to Power Up to Level II	t_power_level2		300	ms	From stop bit low-to-high SDA transition enabling power level II until non-cooled module is fully operational.
Time to Power Down from Level II	t_power_down		300	ms	From stop bit low-to-high SDA transition disabling power level II until module is within power level I requirements.
Tx_Fault assert	Tx_Fault_on		1	ms	From occurrence of fault to assertion of Tx_Fault.
Tx_Fault assert for cooled module	Tx_Fault_on_cooled		50	ms	From occurrence of fault to assertion of Tx_Fault.
Tx_Fault Reset	t_reset	10		μs	Time Tx_Disable must be held high to reset Tx_Fault.
RS0, RS1 rate select timing for FC	t_RS0_FC, t_RS1_FC		500	μs	From assertion till stable output.
RS0, RS1 rate select timing non FC	t_RS0, t_RS1		24	ms	From assertion till stable output.
Rx_LOS assert delay	t_los_on		100	μs	From occurrence of loss of signal to assertion of Rx_LOS.
Rx_LOS negate delay	t_los_off		100	μs	From occurrence of presence of signal to negation of Rx_LOS.

Mechanical Dimensions

Comply with SFF-8432 rev. 5.0, the improved Pluggable form factor specification

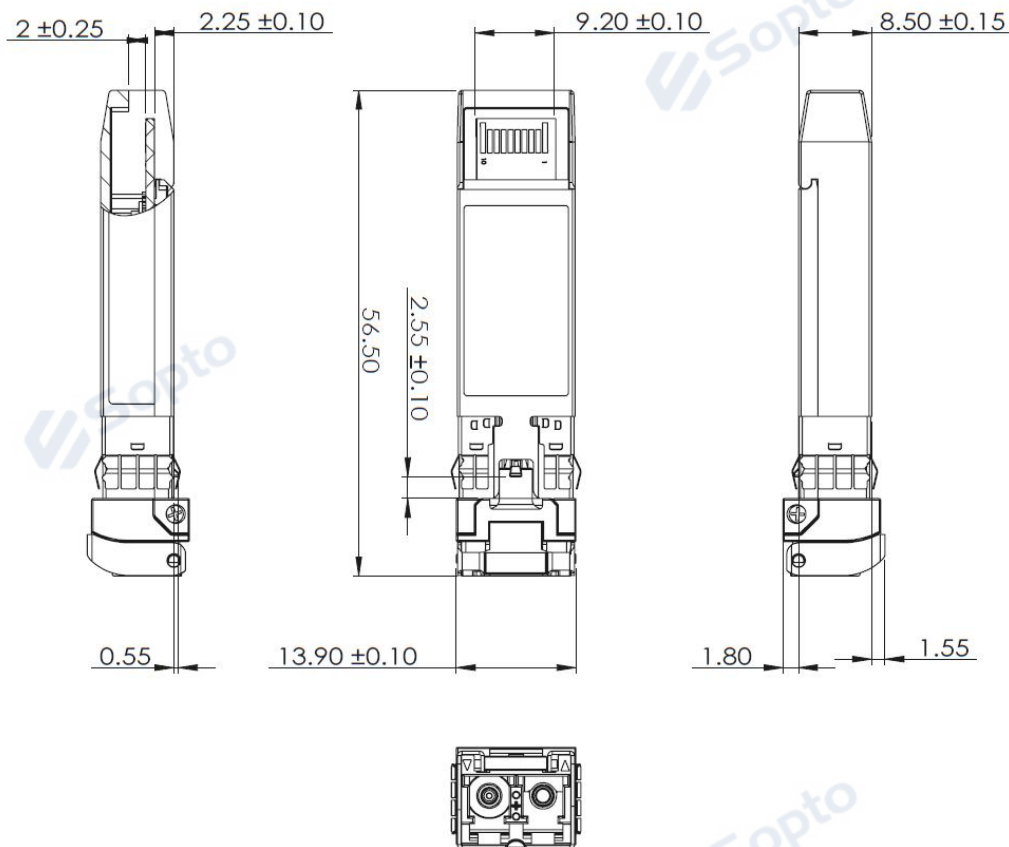

Unit:mm

ESD

This transceiver is specified as ESD threshold 1kV for SFI pins and 2kv for all others electrical input pins, tested per MIL-STD-883, Method 3015.4 /JESD22-A114-A (HBM). However, normal ESD precautions are still required during the handling of this module. This transceiver is shipped in ESD protective packaging. It should be removed from the packaging and handled only in an ESD protected environment.

Laser Safety

This is a Class 1 Laser Product according to IEC 60825-1:2007.This product complies with 21 CFR 1040.10 and 1040.11 except for deviations pursuant to Laser Notice No. 50, dated (June 24, 2007)

Ordering information

Part Number	Product Description
SPT-SFP28-LR	25.78Gbps, 1310nm SFP28 LR 10km, 0°C ~ +70°C
SPT-SFP28-LRT	25.78Gbps, 1310nm SFP28 LR 10km, -40°C ~ +85°C

Note: If you need more customized services, please contact us.

E-mail: info@sopto.com.cn

Web : <http://www.sopto.com.cn>

Sopto

Sopto

Sopto

Sopto